

Uburyo bwo Gukora Umutiba ufite Umupfundikizo w'imbaho



Aba bagore bo mu Mushinga wa Nessuit (Rift Valley muri Kenya), barimo guhoma umutiba bakoresheje amase n'ibyondo

Andi mafoto yatanzwe na Roy Dyche na Paul Latham

Iki gishushanyo kiragaragaza uko umutiba ugomba kuba ungana. Ibipimo by'ifatizo bifasha umuvumvu kwimurira ikimamara mu wundi mutiba. Ibi binamufasha gukora neza mu nzuki mu buryo bumworoheye ndetse bikanamworohera guhakura.

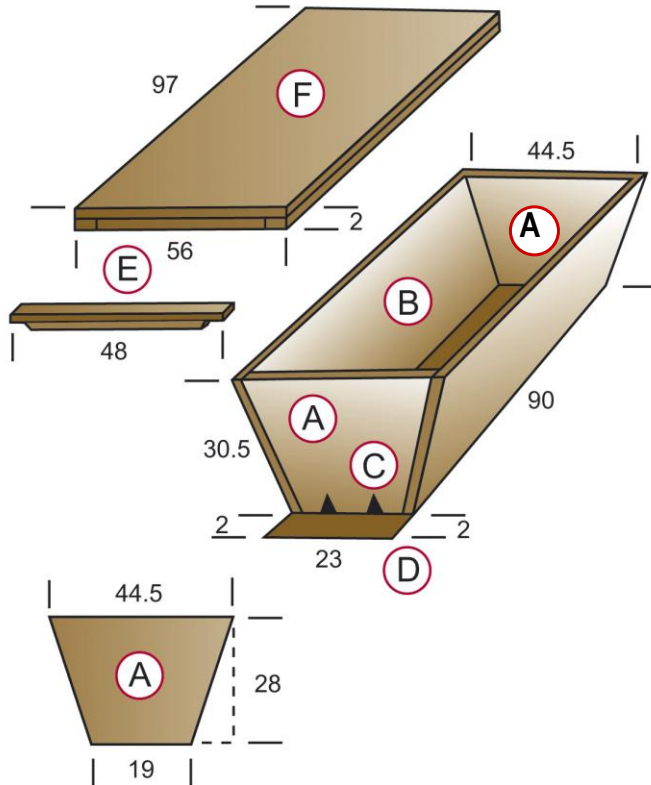

A – Umutwe w'inyuma
 B – Urubaho rwo ku ruhande
 C – Ubwinjiriro (*bukwiriye kuba butarengeje mm 8 z'uburebure*)
 D – Akabaho inzuki zigwaho katarengeje cm 2 z'uburebure (si itegeko kugashyiraho)
 E - Umupfundikizo
 F – Igisenge
(Ibipimo byose biri imbere kugirango byorohe igihe habayeho guhinduranya ibikoresho bikoze umutiba)

Ubusanzwe imbaho zikoze umupfundikizo ziba zifite ishusho ya paralelogaramu. Ni **ngombwa** ko imbaho zikoze umupfundikizo ziba zifite **neza neza** cm 3.2 z'ubutambike:

URUBAHO RUKOZE UMUPFUNDIKIZO URUREBEYE KU MUTWE WARWO

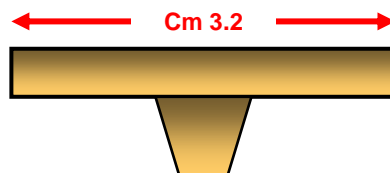

URUBAHO RUKOZE UMUPFUNDIKIZO URUREBEYE KU RUHANDE

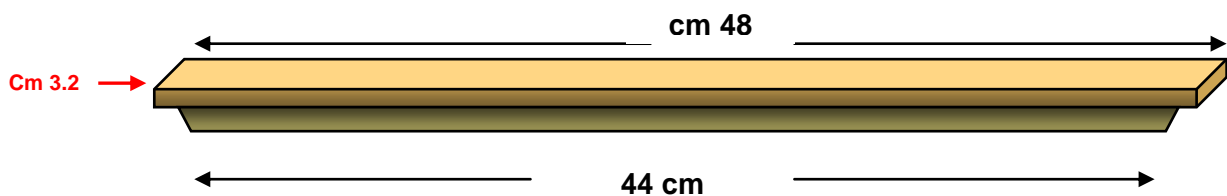

1. GUKORA UMUTIBA MU MBAHO

Kata imbaho watoranije ukurikije ibipimo. Izi ni imbaho zo ku ruhande.



Urubaho rugomba gusenwa kugirango ruze kuringanira n'urundi neza.



Teranya ibice bibiri by'imbaho ukoresheje imisumari kugirango ukore imitwe y'umutiba (umutwe w'imbere n'uw'inyuma). Kata ingofero z'imisumari (cyangwa uzikubitishe ibuye) kugirango impande ebyiri z'umusumari zibe zisongoye. Injiza umutwe w'umusumari usongoye mu rubaho rumwe n'undi mutwe mu rundi rubaho kugirango izo imbaho zombi zifatane.



Izi mbaho ebyiri zifataniye nizo zikora imitwe y'umutiba (uw'imbere n'uw'inyuma).

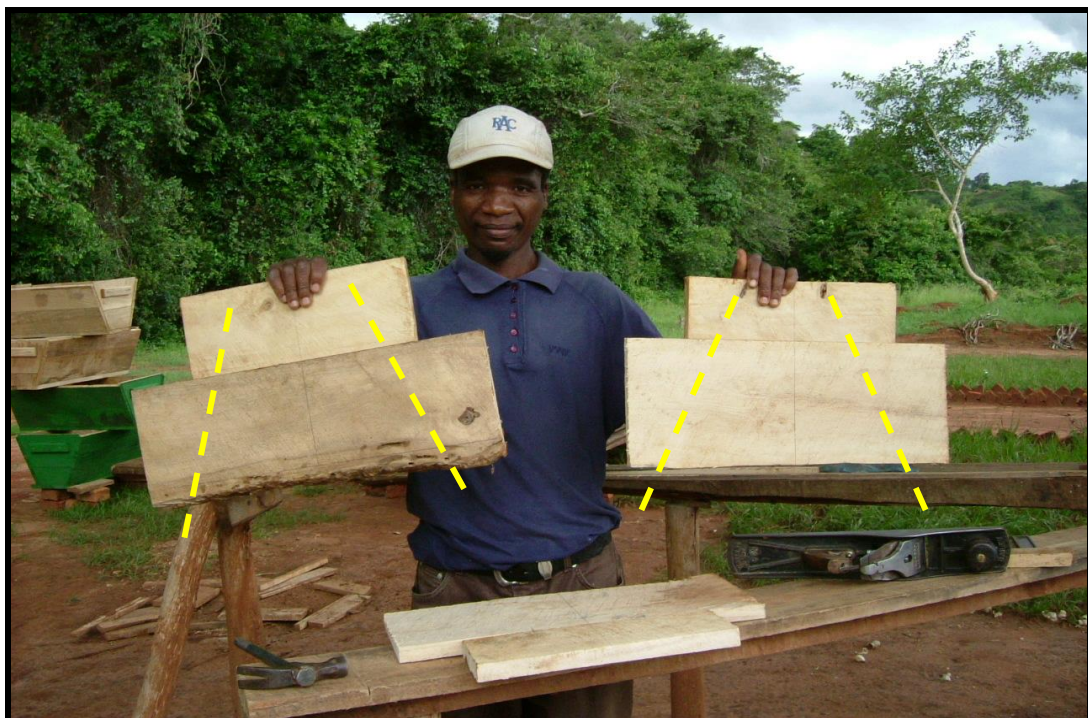

Kata neza imbaho zikora imitwe ukurikije ibipimo.



Koresha igikoresho gifite ibyo bipimo kugirango gupima byorohe. icyo gishushanyo kiba gikozwe mu makarito. Iyo upimye uherye hagati, ntagushidikanya imfuruka ziba ziringaniye neza.

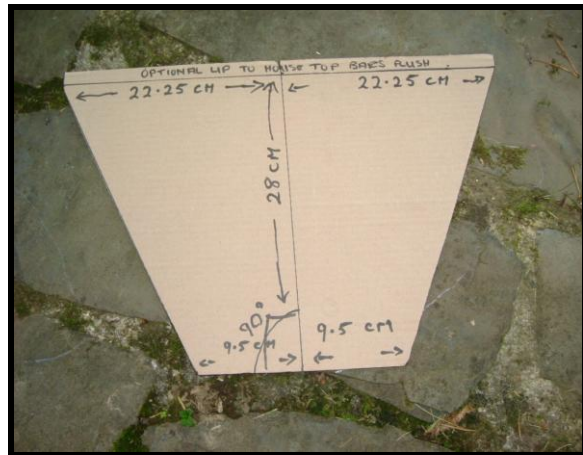

Pfumura umwenge mu ishusho ya 'V' cyangwa upfumure imyenge (intoboro) (ifite umurambararo muto k'uw'ikaramu ya Bic) mu mutwe aho inzuki zinjirira. Ubwinjiriro bugomba kuba butarengeje mm 8 z'uburebure kugirango birinde ibikoko byatera umutiba.



Umaze gukata imbaho, haba hasigaye guteranya umutiba. Kuri iyi foto imbaho ebyiri zo ku mpande zirimo guteranywa n'imitwe. Hanyuma hongerwaho akabaho inzuki zigwaho zinjira.

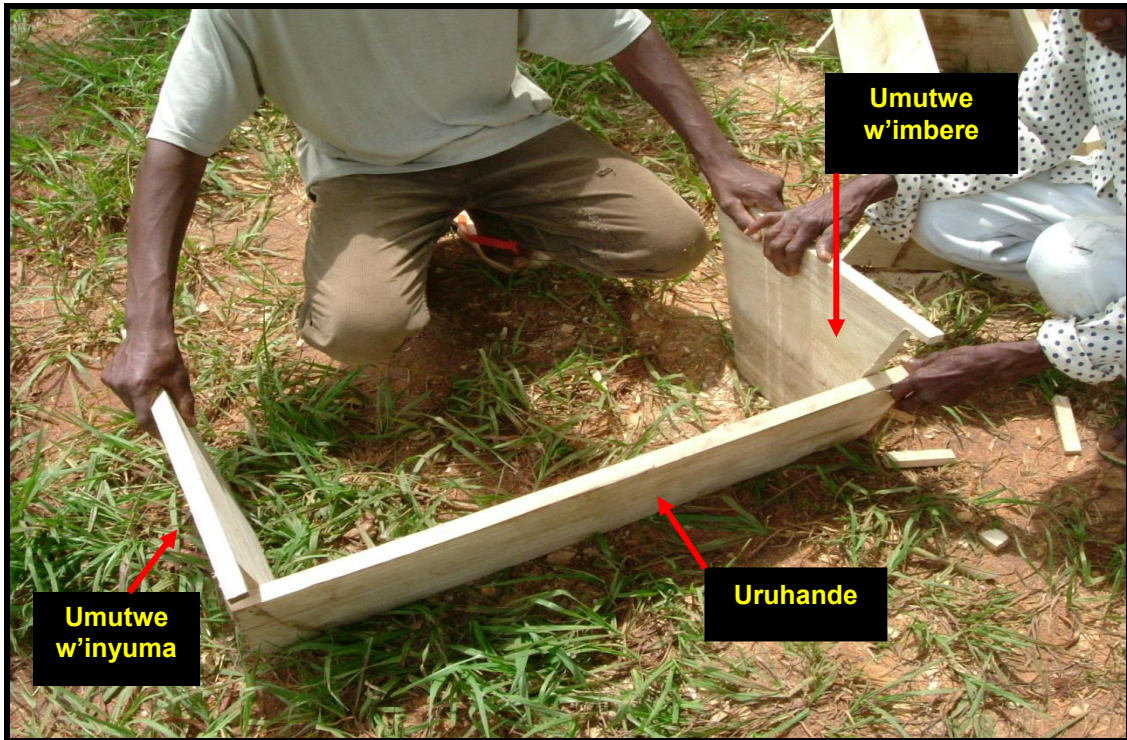

Kubaka igisanduku cy'umutiba.



Hariho bamwe bakora imitiba ifite imitwe isumba imbaho zo ku mpande kugirango imbaho zikoze umupfundikizo zibone aho zijya.



Imbaho zikoze umupfundikizo zikwirwamo neza neza kuko imitwe iba ari miremire.

Abandi bashyira akabaho imbere mu mutiba kugirango imbaho zikoze umupfundikizo zihure neza neza n'impande.



Akabaho izindi zitambikwaho

Imbaho zitambikwa hejuru ziringaniye n'imbaho zo mpande

2. GUKORA UMUTIBA MU BIKORESHO BIHENDUTSE KANDI BIBONEKA MU BURYO BWOROSHYE

Si ngombwa ko imitiba igomba gukorwa mu biti bihenze gusa. Ibikoresho byinshi biboneka mu buryo bworoshye, bishobora gukora umutiba neza. Uyu mutiba ukoze mu giti cy'umukindo wo mu bwoko bwa rafiya (raphia).



Ushobora gukora imitwe y'umutiba ikase neza ukoresheje ibisigazwa by'imbaho (ibiparara), maze impande n'urubaho inzuki zigwaho ukabikoresha ibiti biboneka mu bidukikije. Uyu mutiba ukozwe mu biti bigororotse.



Uyu mutiba witwa "Grande ruche" wo muri Congo ukoranywe ubuhanga hadakoreshejwe imisumari cyangwa imbaho. Ibikoresho byoroshye bifatanishwa uduti dusongoye.



Ibyuho biri muri uyu mutiba ukozwe mu migano, bigomba gupfukanwa ubwitonzi hakoreshajwe ibikoresho bikwirwaho bibuza ibikoko kwinjira.



Uyu mutiba wakorewe mu Bugande ukozwe mu ngeri z'ibiti bihomeshejwe icyondo, ivu n'amase.



Uyu mutiba ukomeye wakorewe i Bugande ubohesheje imbingo.



Imbere h'uyu mutiba no mu mpande zawo hagomba kuba hahomeshejwe icyondo kugirango hekuzamo urumuri no kugirango imiswa n'ibindi bikoko bye kwinjira.



Si ngombwa ko igisenge kiba gikoze mu bikoresho bihenze, gipfa kuba kirinda imvura ngo itagwa mu mutiba. Iki gisenge gitwikirije ishashi.



Iki gisenge gikozwe mu ikadire hamwe n'ibice bibiri by'umugano bigiye bigerekeranije. Mo hagati harimo ishashi ituma amazi atinjira mu mutiba. Hejuru naho hatwikirijwe shitingi.



Iki gisenge gisakaye nk'amazu ya cyera. Gifite imitwe ikomeye irinda inzoka cyangwa ibindi bikoko ngo bitinjira, kinafite imikondo ituma umutiba uterurika ku buryo bworoshye.



Igisenge cy'umutiba gishobora gukorwa mu migano isatuye-nk'uko igisenge cy'iyi nzu yo muri Kenya kimeze.



Umugano usaturwamo ibice bibiri maze bikagerekeranywa gutya-nk'uko ibati rigunnye. Twikiriza umugano ishashi kugirango umutiba urusheho kugira umutekano.



Igisenge giciriritse gishobora gukorwa hakoreshejwe pulasitiki ngari n'ibiti bibiri bicengezwa mu mpande. Uburemere bwabyo butsingira iyo shashi bukayikomeza.

4. Twikiriza amakoma cyangwa ibindi byatsi

2. Umugano uri hejuru ya shitingi wo kuyitsindagira kugirango amazi atembere ku gisenge gicuritse

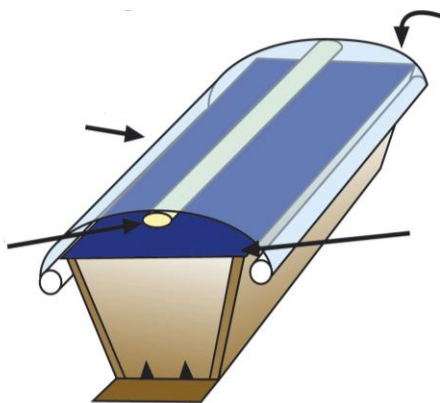

3. Shitingi hamwe n'ibiti bikomeza impande

1. Shitingi itwikiriye imbaho zikoze umupfundikizo w'umutiba

Niba gukora igisenge gifatana n'umutiba bidashoboka, iki gisenge gisakaye gishobora kurinda imitiba ntigerweho n'izuba hamwe n'imvura.

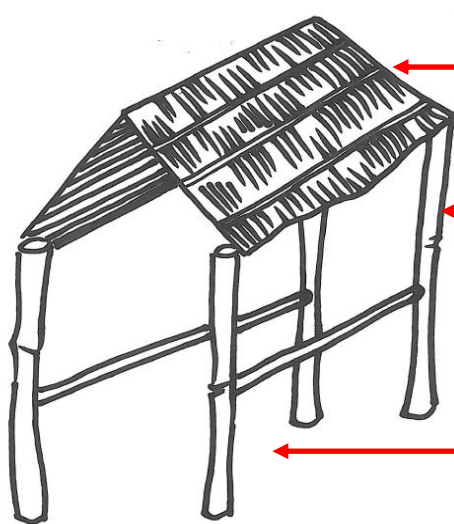

Igisenge gisakaje imikindo gitwikiriye igitereko cy'imitiba

Ibiti by'imigano bifashe igitereko cy'imitiba

Umutiba ushyirwa aho utwikiriwe

Uyu mutiba ukoze mu biti wuzuye ushyirwa mu gitereko cyawo gikozwe mu biti birebire bihambirijwe insinga. Ibi bituma imitiba imanikwa mu buryo bworoshye bikanarinda ko ibikoresho biwukoze byoroshye byangirika. Kwimura imitiba uyiterura mu gitereko cyayo, bituma kugabanya inzuki byoroha.



Insinga zimanitse umutiba.

Ikadire ikozwe mu biti bihambiranije hamwe niyo iterekwamo umutiba.

3. GUKORA URUBAHO RWO HEJURU

Gukata urubaho rw'umutambiko ikimamara gifataho nicyo gice gikomera kandi kinahenda mu gihe ukora umutiba. Ni ngombwa ko izo mbaho ziba zifite mm 32 cyangwa 33 (cm 3.2 cyangwa 3.3) z'ubugari. Gupima ubugari bw'imbaho zitambikwa hejuru hakoreshwa umupfundikizo w'icupa cyangwa ibuye ry'iradiyo rya volute 9 ryarangije gukoreshwa (amabuye afite impande enye niyo akoresha gusa).



Imbaho nyinshi zitambikwa hejuru zikatwa mu mpande. Nyamara, abantu benshi bakoresha neza imbaho zitambikwa hejuru ziciriritse, bazikoze mu bikoresho biborohera kuboneka kandi byoroshye gukatwa aho gukoresha imbaho zihenze. Uyu mutambiko ikimamara gifataho ukoze mu giti cy'umukindo wo mu bwoko bwa rafiya (raphia).



Uru rubaho ntirufite inguni. Rurarambuye.



Ibiti, imigano cyangwa ibindi bikoresho bikwiriye, bikatanwa ubwitonzi kandi bigakatwa neza.



Urubaho ibimamara bifataho rutonyangirizwaho amazi ya buji ikoze mu bishashara.



Itegereze iyi foto. Ushobora kubiganiraho n'abandi bavumvu. Iyi mitambiko iri ku mutiba ikozwe mu migano, iriho amavuta y'ibishashara; iki ni igitekerezo cyiza nawe ubwawe wagerageza. Ariko kandi, bizagora umuvumvu igihe inzuki zizashyira ikimamara ku mutambiko kandi izo mbaho zidakase neza.



Imbaho zitambikwa ku mutiba zikase nabi nizo zituma ibibazo byinshi bishobora kuvuka igihe ukoresha imitiba itambikwaho imbaho hejuru.

Iyo utubaho cyangwa amarati atambikwa ku mutiba akaswe neza akanashyirwaho amavuta y'ibishashara neza, inzuki zubaka ikimamara kuri buri rati itambikwa ku mutiba. Ibi bifasha umuvumvu gusarura mu buryo bumworoheye no kwimura ibimamara abivana mu mutiba umwe abishyira mu wundi kugirango akore neza mu nzuki kimwe niyo akora mu mitiba ya kizungu (imitiba y'amakadire).

