

Aerial Ropeways of Nepal

Introduction

Nepal possesses extreme geographical conditions ranging from high hills and mountains to areas of flat land known as the *terai*. Rugged terrains, unfavourable weather conditions and scattered settlements in the hilly and mountainous regions obstruct the mobility of people and the transporting of goods and services as well as hindering development efforts. Rural access is a major problem in Nepal. Settlements are scattered, with few densely populated areas.



Rural Nepal
Photo: Practical Action

In such a harsh mountainous region the construction of roads is expensive and time-consuming. The cost of transporting construction materials by is high, and damage from landslides is common. The gravity ropeway is therefore a viable alternative in many locations.

Practical Action Nepal commenced its transport programme in 1998. It improved and promoted innovative transportation systems, such as cable river crossing bridges known as *tuin*, gravity ropeways for hilly and mountainous regions and bicycle ambulances and trailers for the *terai* regions.



Ropeway transport system
Photo: Practical Action

Ropeway transport has been in use in Nepal for many years. In its most basic form it consists of a single span made with fibre rope, simply anchored at each end. The first major ropeway in Nepal was installed in the 1920s, followed by an improved and extended system in 1964. Although there has been some stagnation in the development of large-scale ropeways, small-scale systems remain economically feasible in the country.

Practical Action has also been instrumental in setting up a National Forum for Rural Transport and Development, under the International Forum for Rural Transport and Development (IFRTD) umbrella.

Practical Action, The Schumacher Centre for Technology and Development, Bourton on Dunsmore, Rugby,
Warwickshire, CV23 9QZ, UK
T +44 (0)1926 634400 | F +44 (0)1926 634401 | E infoserv@practicalaction.org.uk | W www.practicalaction.org

Practical Action is a registered charity and company limited by guarantee.
Company Reg. No. 871954, England | Reg. Charity No.247257 | VAT No. 880 9924 76 |
Patron HRH The Prince of Wales, KG, KT, GCB

Ropeways

Gravity ropeway technology was transferred from Northern India to Nepal by Practical Action Nepal in collaboration with the International Center for Integrated Mountain Development (ICIMOD). In partnership with ICIMOD and a private manufacturer-supplier, Practical Action Nepal installed a couple of demonstration ropeways in Marpha and Tukche VDCs of Mustang district to facilitate the transportation of apples from orchards to the road-heads. After a successful intervention in Mustang, Practical Action Nepal installed the Janagaon- Bishaltar Ropeway in Benighat VDC, the Hadikhola-Chiraudi Ropeway in Kalleri VDC of Dhading district, and the Torisawara-Bishaltar Ropeway in Torisawara VDC of Gorkha district (with financial support from The European Union, and UK Trusts and Foundations).

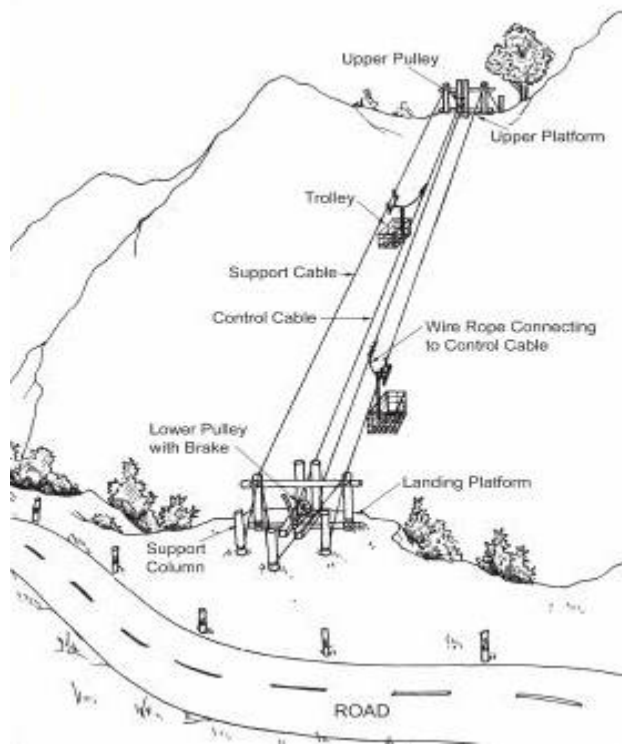

An initial study showed that the transportation cost of agro-based products decreases by at least 50% once served by a gravity ropeway system. Such encouraging statistics have villagers the confidence to supply their products in larger amounts, and to enter competitive city markets. Access to a transportation system and to market linkages improves their socio-economic status in terms of income, health, education and community awareness. Promotion of this technology also helps the local economy by creating employment opportunities and by supporting local manufacturers and service providers.

The Principle

The gravity ropeway is an inexpensive and simple means of transportation. It operates by gravitational force without the use of external power. The gravity ropeway consists of two trolleys which roll on support tracks. These are attached to a control cable in the middle which moves in a traditional flywheel system. When the loaded trolley at the up-station is pulled downward by the force of gravity, the other trolley at the bottom-station is pulled up automatically by means of the control cable. In principal the goods coming downward from the up-station must to be thrice as heavy as the up-going load. The sliding down of the trolley and its speed depends upon the angle of elevation made by the cables installed with the horizontal ground.

A flywheel with bearing and bracket is used as a brake to control the landing speed of the trolley at the bottom-station. Communication between top and bottom stations is done by tapping the wire rope. The operator at the top-station strikes the wire rope with a stick to send a wave signal through the wire



A typical braking system
Photo: Practical Action / Upendra Shrestha

technical brief

rope to the operator at the down-station. The operator at the down-station then applies the hand brake to control the flywheel.

Cost

The cost primarily depends upon the local topography, angle of inclination, the ropeway span at inclination between the two stations, and use of local raw materials and construction technology.

Braking system

The braking system is used to control the speed of the trolley during landing at the down platform. This is done by applying force to the handle. Brake strips are connected to a fixed support at one end, and to the brake handle at the other end.

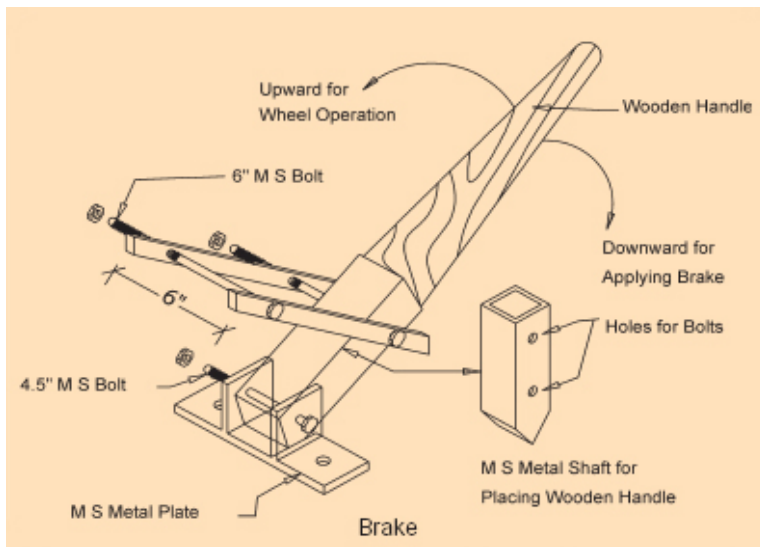
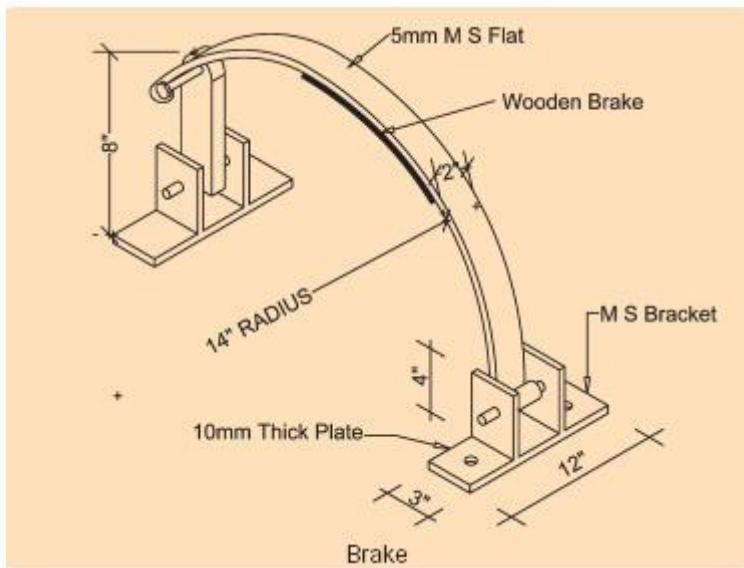

Trolley guide pulley system

The trolley guide pulley system guides and provides cushioning effect to the support wire rope, as well as converting gravitational force into kinetic energy. The system consists of a pulley guide and a dummy pulley attached to the supporting channel. The wire rope slides between the two pulleys. The ring connected to the trolley hanger is also attached to the pulleys.

technical brief

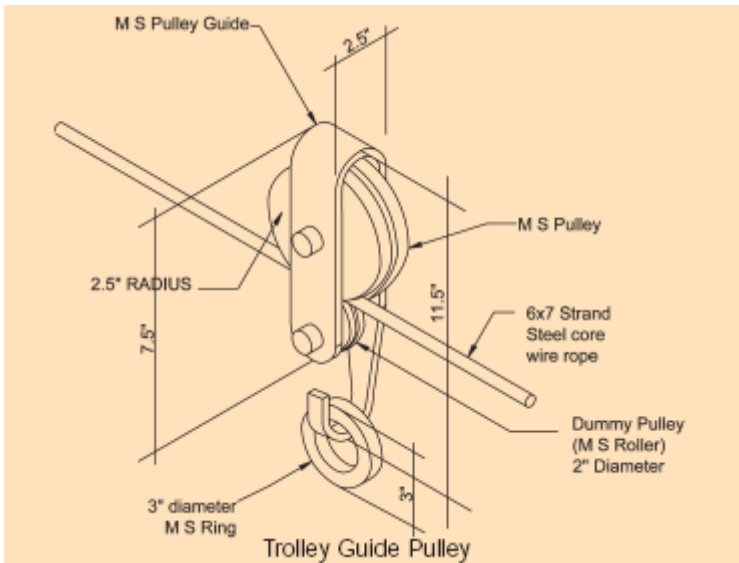

Trolley

The trolley is made from mild steel (MS) pipes, and has a hanging trolley box where the load is placed. The flexible supporting hanger is connected to the guide pulley system. Its weight should be as light as possible – say, 30 kg. The center of gravity of the trolley should be well-balanced during operation.

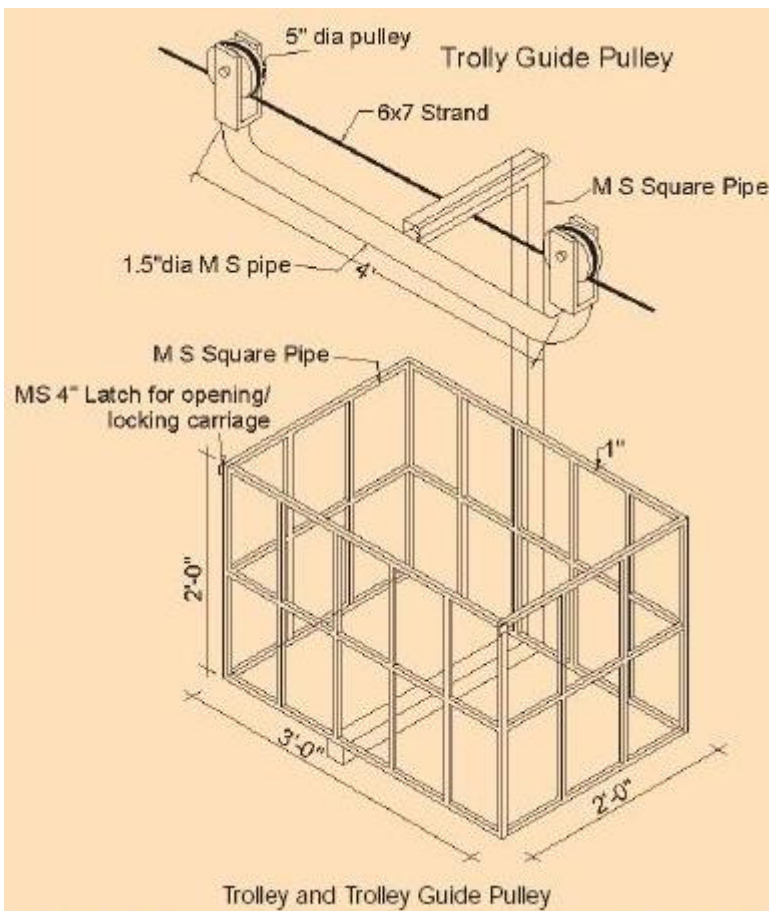

Up- and down-station platforms

The up-station and the down-station platforms are civil foundations housing the control pulley, the supporting cable, the braking system and other functioning structures. Both stations are used as loading and unloading platforms. The civil structure and foundation

should be stable enough to bear all the impact and operating load of the system. This can be constructed of dry timber, iron beams and/or concrete structures, depending upon availability of raw materials and technology. Concrete construction makes the structure more stable, which in turn allows the ropeway alignment to be stable.

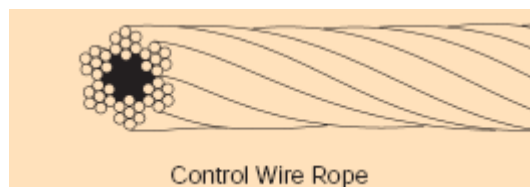
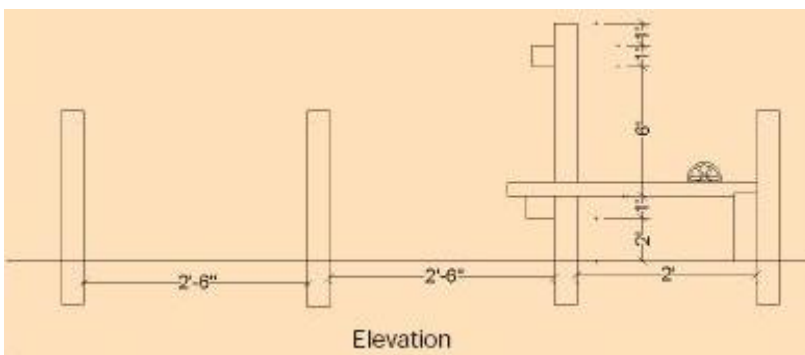
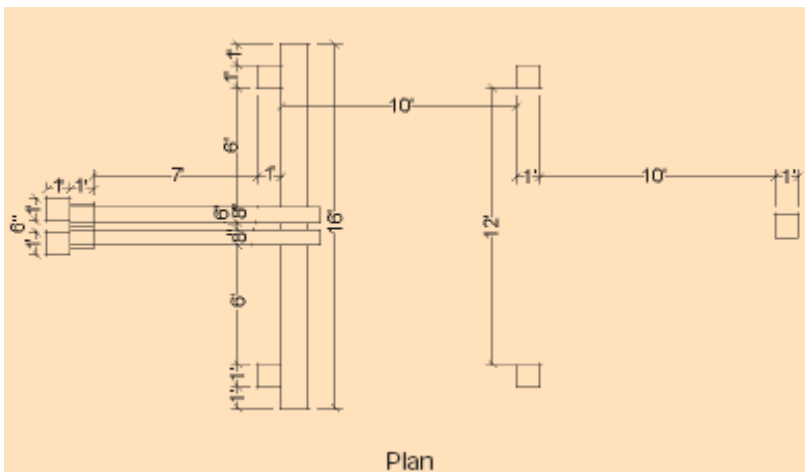
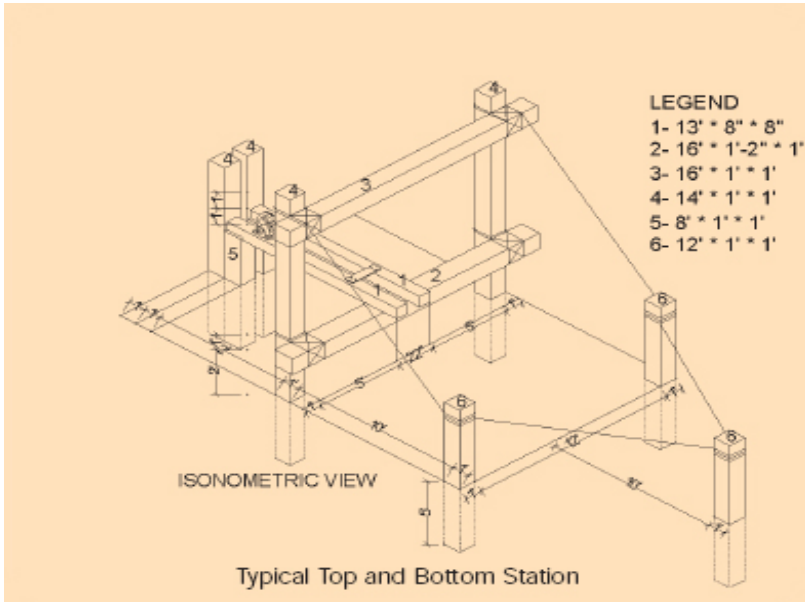

technical brief

Support and control wire rope

Specifications

- 6x7 strand steel core F 10-12mm wire rope for support cable
- 6x7 strand jute core F 8-10mm wire rope for control cable
- The factor of safety should be at least 3 or more

$$T = \frac{((2 * W + w * L + Ww * L) * l) / (8 * b)}{\cos \beta}$$

T = Total load on the cable

W = Weight of loaded trolley (kg)

Ww = Wind load factor (kg/m²)

w = specific weight of wire rope (kg/m²)

β = cable inclination with saddle point

L = $l [1 + 0.5 * \{ (h / l)^2 \} + 8/3 * \{ (b / l)^2 \}] + L_b$

b = $l * h / (8 * e * l)$

where,

L = Total length of the wire rope

b = Sagging at mid-way from highest point

e = Lowest point horizontal distance from highest point

l = Horizontal distance

h = Vertical distance

L_b = Backstay length at up station and down station

Functions and components of the gravity ropeway

Top-station control pulley

The top-station control pulley is used to control and guide the control wire rope at the top-station. It is supported at the end by two bearings, and the housing is fixed rigidly on the base frame of the platform.

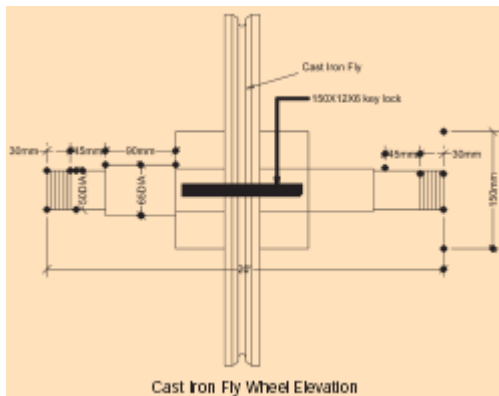

Down-station control pulley and fly wheel

The down-station control pulley and fly wheel are used to control and guide the control wire rope at the down-station. They are supported at the end with two bearings, and the housing is fixed rigidly on the base frame of the platform. The fly wheel ensures smooth motion along the wire rope.

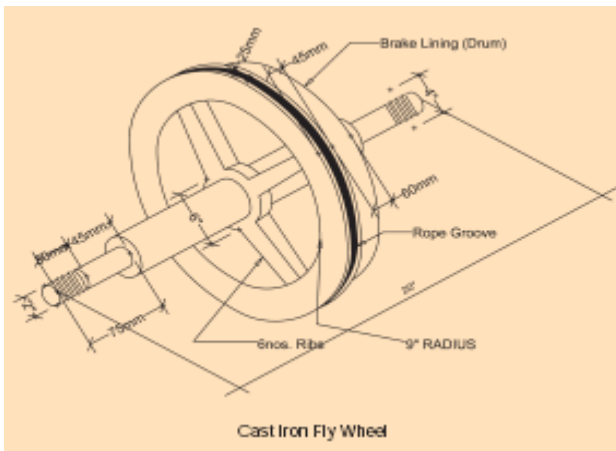
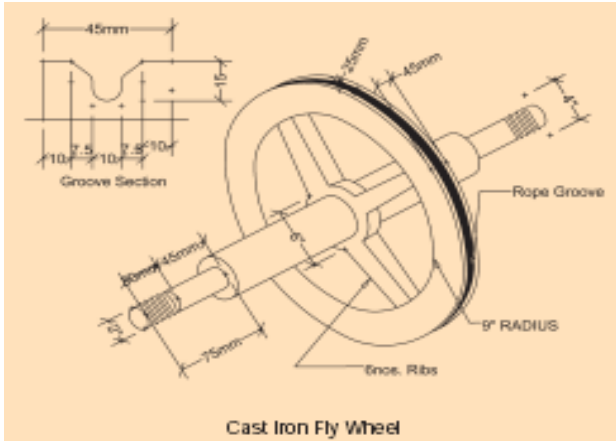

Bearing and housing

The bearing and the housing are used to support and provide free movement to the shaft, which contains the control pulley. For this purpose, an SKF Roller bearing No. 6212 (with corresponding bearing housing) are used.

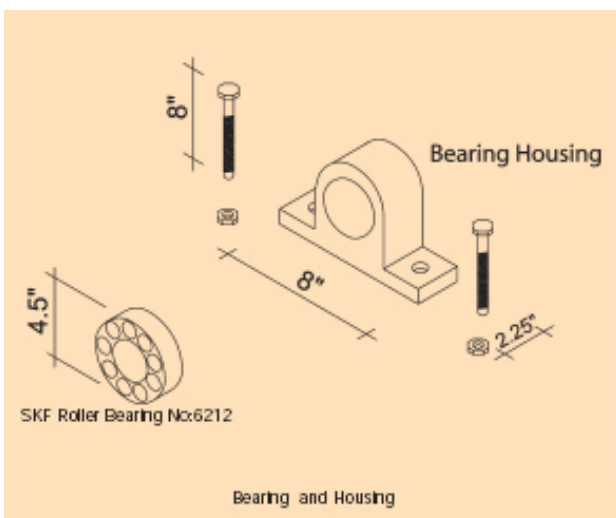

Tuin

Wire Bridges (*Tuin*) are an indigenous technology, and one of the most common structures for river crossing in the hilly regions of rural Nepal. There are more than 6000 rivers in Nepal, most of them with no means of crossing. Many people die trying to cross during the monsoon season.

There are more than 15 *tuin* in operation along the Trisuli River, each one serving approximately 50 households (300 people).



Tuin is the main means of river crossing for the people of Kalleri Village, Dhading

Photo: U. Shrestha / Practical Action Nepal

The new design of *tuin*

Practical Action Nepal has conducted a study looking to improve the existing technology. Ideas for improving the design came from the local community during discussions with Practical Action technical experts. The community expressed concerns about the safety of traditional *tuins*. Many people have lost fingers while operating *tuins*, and there also is the danger of falling out of a trolley while crossing a river. Practical Action has come up with low-cost improvements that address users' concerns.



Photo: Practical Action

One of the first changes was to develop a safe trolley to prevent people falling out. Seats were added and sidebars installed. Practical Action Nepal then went on to develop a new pulley system that makes pulling the trolley easier and eliminates the risk of trapping fingers in the mechanism. The pulley and bearing system also reduces friction and lessens the effort required to cross the river, doubling the overall efficiency.



Photo: Practical Action

The improved *tuin* was developed and tested at the village of Mahestar (about 60 km west of Kathmandu). Based on the experience gained here, the design has been further developed into a double-cable design. Although costing more it provides better balance and can carry a greater load. Double-cable prototypes have been built in the villages of Kalleri, Pimaltar and Balkhu, in Nepal's Dhading district.



Photo: Practical Action

The costs involved in the construction of an improved *tuin* are:

- labour
- manufacturing
- *tuin* support system (pillar construction)
- wire cable
- *tuin* trolley
- pulley system
- anchor block and other accessories
- installation
- equipment transportation

The improved *tuin* is intended for areas where other forms of river-crossing are inappropriate or too expensive.

References

- *An Evaluation of a Micro-hydro Powered Ropeway in Nepal*
A. L. S. Duignan, Centre for Environmental Technology, Imperial College of Science, Technology & Medicine, University of London, 1998.
- *Ropeways in Nepal: Conceptual Analysis of Context and Viability, Interdisciplinary Analysis*, ITDG Nepal, 1996.

Further information

Practical Action Nepal
P.O.Box 15135
Kupandol
Lalitpur
Kathmandu
Nepal
Tel: 977-1-4446015/4434482,
Fax: 977-1-4445995,
Email: info@practicalaction.org.np
E-mail: practicalaction@practicalaction.org.np
www.practicalaction.org

International Forum for Rural Transport and Development
IFRTD
2 Spitfire Studios
67-73 Collier Street
London N1 9BE
United Kingdom
Tel: +44 (0)20 7713 6699
Fax: +44 (0)20 7713 8290
E-mail: ifrtd@ifrtd.org
Website: <http://www.ifrtd.org>

The International Forum for Rural Transport and Development is a global network of individuals and representatives from government, academia, multilateral and bilateral donor agencies, consultancies and technical institutions, national and international NGOs and groups of community organisations.

Nepal Net
an electronic networking for sustainable development in Nepal
http://www.panasia.org.sg/nepalnet/technology/hydro_trans.htm

Service Providers

For wire ropes of ISI standard
Usha Martin Industries Limited
14 Princep Street, Calcutta 700 072, India
Tel: 27-2203

Navin Steel Industries
Dhangu Road, Pathankot – 145001, India
Tel: 01893-244690, Fax: 01893-24408

For wire rope accessories
Navin Steel Industries
Dhangu Road, Pathankot – 145001, India
Tel: 01893-244690, Fax: 01893-24408

Installation Support
Ambika Fabrication and Repairing Pvt. Ltd.
Bhaktapur, Katunje, Ward No. 9, Sallaghari, Tinkune
Ph: 977-1-6610353
Contact Person: Doordam Thapa
Cell Ph: 9851052853

Structo Nepal Pvt. Ltd.
P.O. Box: 228, Block No. 27,
Patan Industrial Estate, Patan
Ph: 977-1-5521192, Fax: 977-1-5542118
Contact Person: Rajendra Pradhan

Appropriate Technology Development and Goods Manufacturing Industries (ATDGM)
Balaju Industrial Estate,
Balaju, Kathmandu
Tel: 977-1-4356191
E-mail: shankar@manjee.wlink.com.np

Practical Action
The Schumacher Centre for Technology and Development
Bourton-on-Dunsmore
Rugby, Warwickshire, CV23 9QZ
United Kingdom
Tel: +44 (0)1926 634400
Fax: +44 (0)1926 634401
E-mail: inforseiv@practicalaction.org.uk
Website: <http://practicalaction.org/practicalanswers/>

Practical Action is a development charity with a difference. We know the simplest ideas can have the most profound, life-changing effect on poor people across the world. For over 40 years, we have been working closely with some of the world's poorest people - using simple technology to fight poverty and transform their lives for the better. We currently work in 15 countries in Africa, South Asia and Latin America.

technical brief