

# Walls: Using Interlocking Stabilised Soil Blocks

## Introduction

This technology has distinct advantages over hollow concrete blocks as well as fired bricks. It offers greater structural stability by having 'keys' which interlock with other blocks when constructing walls and columns. Walls constructed using this technology is more resistant to damage caused by natural disasters such as cyclones, earthquakes and floods.

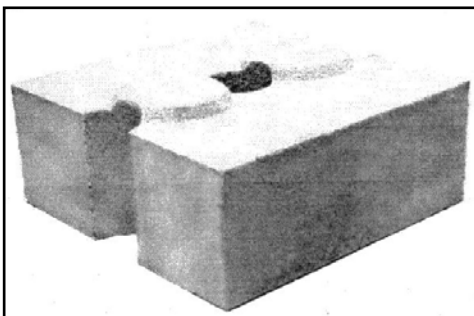

The interlocking blocks are also more eco-friendly than concrete blocks or fired brick as they are made of earth; consumes less energy to produce and causes less pollution. It requires less mortar than concrete blocks or fired bricks and thus results in cost savings. These interlocking blocks can be used to construct 4 ½" walls. It reduces the labour cost as well.

## The Technology

- Remove top soil & leave it aside for re-use.
- Proportions of the mix: gravel 15%, sand 50%, silt 15% and clay 20%. Soil tests need to be undertaken as follows ;

## Sensitive Tests

### Visual examination

The dry soil is examined with the naked eye to estimate the relative proportions of the sandy and fine fractions. Large stones, gravel, and coarse sand are removed in order to

facilitate evaluation. The fines fraction is made up of grain sizes with a diameter of less than 0.08 mm. This diameter lies at the limit of the resolving power of the human eye.



### Smell test

The soil should be smelt immediately after removal. If it smells musty it contain organic matter. This smell will become stronger if the soil is heated or wetted.



Contact: Resource Desk at

## Practical Action

No 5, Lionel Edirisinghe Mw, Colombo 5, Sri Lanka.

T +94 (11) 2829412 F +94 (11) 2856188

W [www.practicalaction.org](http://www.practicalaction.org) [www.janathakshan.net](http://www.janathakshan.net) E [srilanka@practicalaction.org.lk](mailto:srilanka@practicalaction.org.lk)

## Nibble test



The tester nibble a pinch of soil, crushing it lightly between the teeth. The soil is sandy if it grinds between the teeth with a disagreeable sensation. Silty soil can be ground between the teeth but without giving a disagreeable sensation. Clayey soil gives a smooth on floury

sensation and a small piece of it is sticky when applied to the tongue. Of course care should be taken that it is safe to place any such samples in the mouth.

## Touch test

After removing the largest grains, crumble the soil by rubbing the same between the fingers and the palm of the hand. The soil is sandy if a rough sensation is felt, and has no cohesion when moist. The soil is silty if it gives a slightly rough sensation and is moderately cohesive when moistened. The soil is clayey, if when dry it contains lumps or concretions which resist crushing and if it becomes plastic and sticky when it is moistened.



## Washing test

Wash the hands with the slightly moistened soil. The soil is sandy if the hands easily rinse clean. The soil is silty if it appears to be powdery and the hands can be rinsed clean without any great difficulty. The soil is clayey if it gives a clayey sensation and the hands can be rinsed clean only with difficulty.



## Lustre test

A slightly moist ball of earth is cut in two with a knife, if the freshly revealed surface is dull, the soil will be predominantly silty. A shiny surface on the other indicates the presence of a plastic clayey soil.

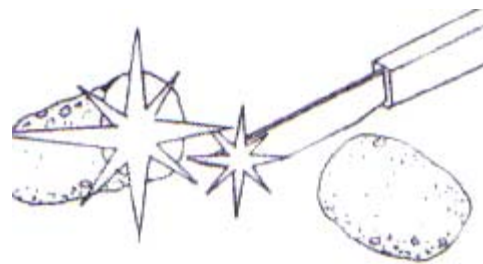

Source: Production & use of Compressed Earth Blocks – published by the Auroville Building Centre, India

Sieve the soil & commence production of the earth blocks according to the following steps.

## The screening

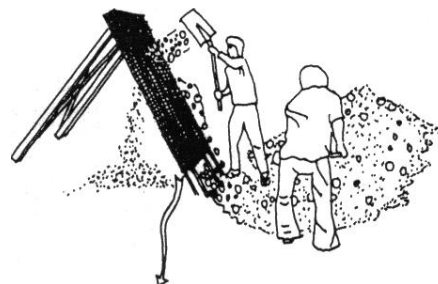

Throw the soil at the top part of the screen (dim.1/2)



Size of the wire mesh: 1 cm X 1 cm

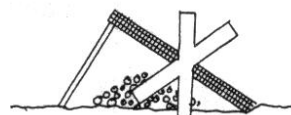

Not good  
Too flat: big gravel goes through the screen



Not good  
Too vertical: very thin soils go through the screen

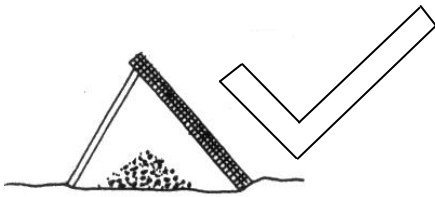

Good  
Correct angle: Well screened soil

Source: Production & use of Compressed Earth Blocks – published by the Auroville Building Centre, India

## The measuring



Fill buckets and wheel barrow Sand

Screened soil

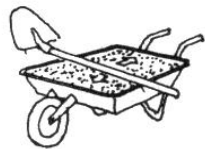

Smooth the top



Deliver on the mixing area



How to find the measurements of soil, sand, cement (See stabilization calculation p.46 to 49)

## The dry mixing



Pour the cement pile of soil

Mix the soil and the cement



Move the pile 2 or 3 times to obtain a uniform color

## The humid mixing

Sprinkle water on a dry pile



Mix again the humid pile



Sprinkle water and mix again to obtain a uniform colour and texture.



Source: Production & use of Compressed Earth Blocks – published by the Auroville Building Centre, India

Not good, The ball does not break: Too wet

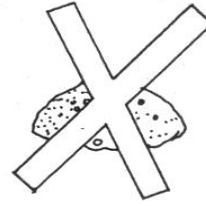

Source: Production & use of Compressed Earth Blocks – published by the Auroville Building Centre, India

## Check the moisture content

Let fall a squeezed ball from 1m high and observe the result

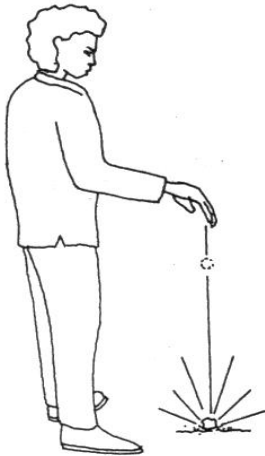

Not good, The ball bursts a part: Too dry

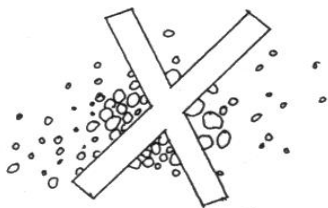

Good, The ball bursts into 4 or 5 pieces: Good moisture content

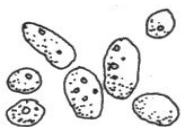

## The moulding

Fill the scoop with mixed soil



Fill the mould

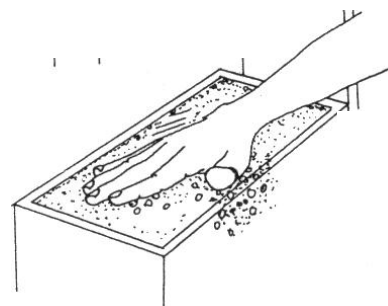

Level the mould

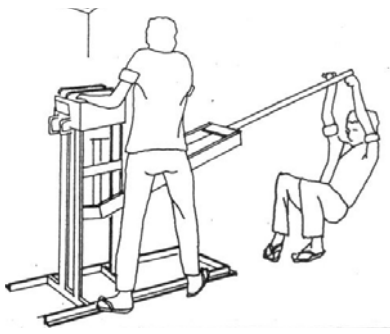

Press

## Special blocks moulding

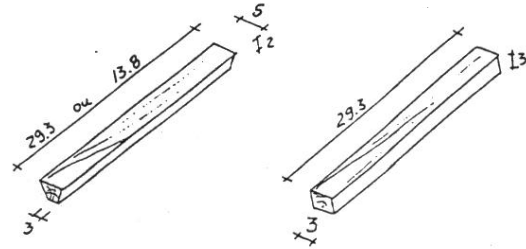

## Special blocks moulding

Wooden shape for the beam

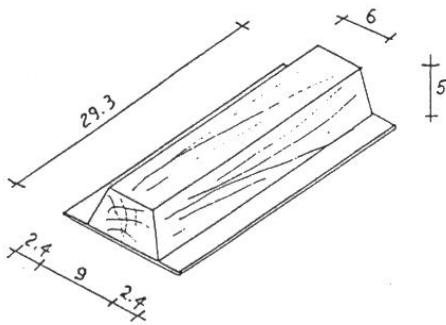

Wooden shapes for electrical blocks

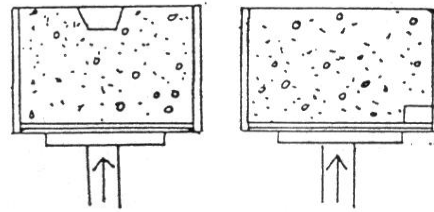

How to put the wooden shapes into the mould

Handle the beam block with the wooden shape till the curing area

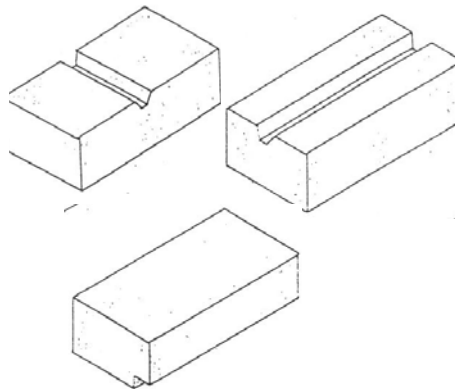
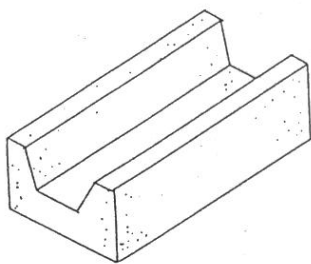

Examples of blocks

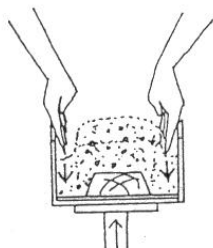

Compress the soil at the edges with the hands

## The final storage

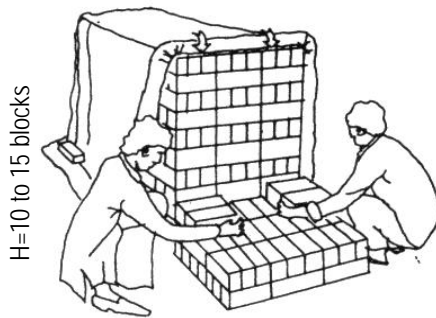

Each early morning move the 2 days old blocks from the humid curing to the final storage with all team



Sprinkle the blocks

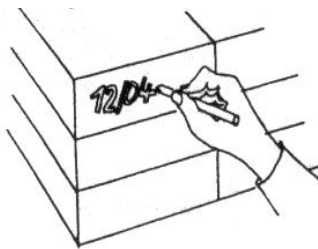

Blocks corner

Cover with thick plastic during 7 days

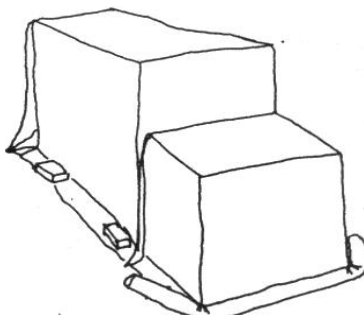

## The humid curing

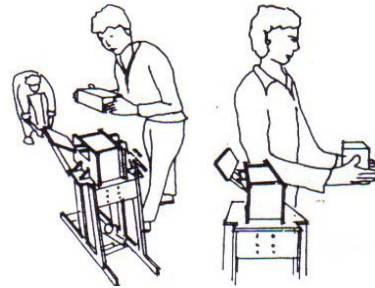

Handle the block with care

Store the block and unroll directly the thick plastic sheet

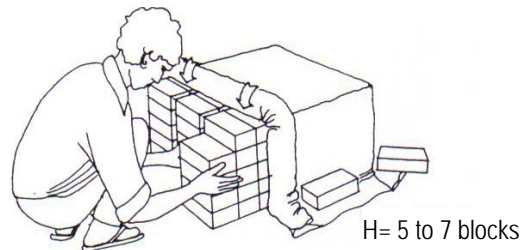

The pile will stay 2 days and nights under a plastic sheet:  
During this humid curing the blocks are very fragile

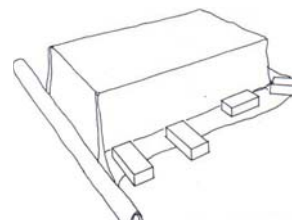

For earthquake resistance, the brick should be manufactured by mixing in cement (min 5% depending on soil condition) and lime 5%. Suitability of stabilisers and their percentages.

	suitability	Min. %	Ave. %	Max. %
cement	Mostly for sandy soil	5%	7%	No technical maximum. Economic maximum 9-10%
lime	Mostly for clayey soil	5%	8%	10%

(Source: earthquake resistant buildings with hollow interlocking blocks published by the Auroville Earth Institute, India. www.earth-auroville.com.)

## Quality control

It is essential that the blocks are subject to quality control checks before using in construction. Details of several QC checks are set out in Chapter 6 of the book on *The Production & use of compressed earth blocks*- published by the Auroville Building Centre India), some of which are set out below.

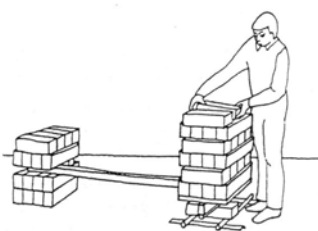

The production should be checked daily at every stage of the production cycle with simple tests as given in the table below. Field tests can be undertaken either weekly or monthly substantiated by regular laboratory tests on samples.

Source: Production and Use of Compressed Earth Blocks published by the Auroville Building Center

Stages	What to control	Means
Soil supply	<ul style="list-style-type: none"> <li>• Top soil must be removed</li> <li>• Check the regularity of supply</li> <li>• Check the depth of veins</li> <li>• If supply with lorries , check before unloading</li> <li>• Adapt the mix of small change in soil supply</li> </ul>	<ul style="list-style-type: none"> <li>• Sensitive tests</li> <li>• Eventually laboratory tests if soil changes too much</li> </ul>

Measuring	<ul style="list-style-type: none"> <li>• Check that contains are filled according to requirement</li> <li>• Bags of cement poured in 3 or 4 buckets at a time</li> </ul>	<ul style="list-style-type: none"> <li>• look</li> </ul>
Dry mixing	<ul style="list-style-type: none"> <li>• Move 2 times minimum the piles</li> <li>• Check the uniformity and homogeneity of mix (especially the colour)</li> <li>• Check if big lump</li> </ul>	<ul style="list-style-type: none"> <li>• look</li> </ul>
Wet mix	<ul style="list-style-type: none"> <li>• Move 2 times minimum the piles</li> <li>• Check the uniformity and homogeneity of mix (especially the colour)</li> <li>• Check the lumps</li> <li>• Check the moisture content</li> </ul>	<ul style="list-style-type: none"> <li>• Look</li> <li>• Sensitive test</li> <li>• Once in a while : laboratory test according to OMC /proctor test</li> </ul>
moulding	<ul style="list-style-type: none"> <li>• Height</li> <li>• Strength</li> <li>• Weight</li> <li>• Texture (loose or dense)</li> <li>• External look (edges, corners difference in colour.....)</li> </ul>	<ul style="list-style-type: none"> <li>• Meter tape</li> <li>• Penetrometre</li> <li>• Scale</li> <li>• Look</li> <li>• look</li> </ul>
Wet cutting	<ul style="list-style-type: none"> <li>• Stacking according to requirement</li> <li>• Cleaning the ground</li> <li>• Covering with</li> </ul>	<ul style="list-style-type: none"> <li>• look</li> </ul>

	plastic sheet • Edges after stacking • Space left in between blocks	
Stacking and final curing	• Care for stacking • Care for transport • Stacking according to requirement • Protection with kit leaves • Water twice daily minimum • Storage for 4 weeks before use	• look

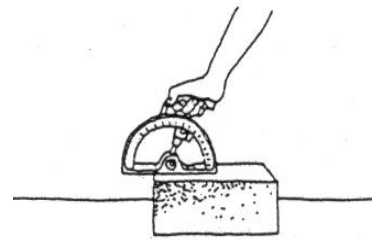

Pendulum scleroscope

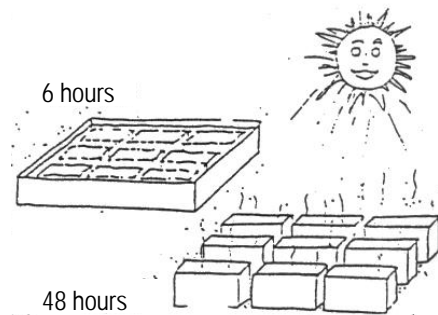

Soaking into water then drying

## field teste

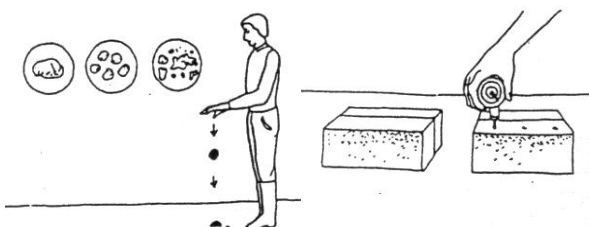

Optimal moisture content

Penetrometre

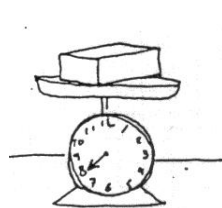

Weight

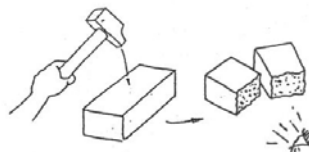

Visual examination

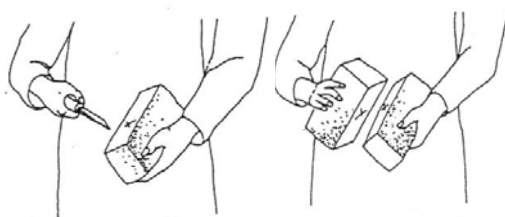

Penetration

Impact

## Building the wall using the brick

- A thin mix (which is earthquake resistant) should be used to bind the blocks. The mix should be used at a thickness not greater than 3mm to ensure adequate interlocking. The mix is made up of cement, sand, clay (1 cement: 3 sand: 3 clay) as opposed to the normal proportions of 1 cement: 6 sand: 6 clay.
- Reinforcements should include 6mm mild steel bar at every 4th hole, as given below;

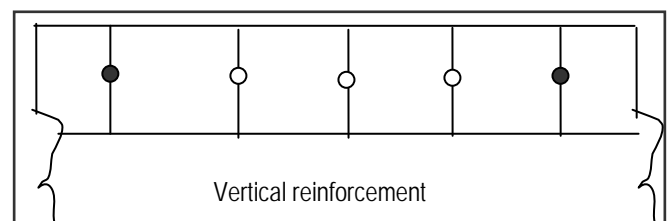

- A chip (aggregate chips) concrete should be used with a 1:2:4
- Mix An interlocking Block of 6" width is suitable for single storey buildings, while a 9" block is suitable for a two storey building and above. The double brick may be used for up to 3 floors without the use of structural columns.

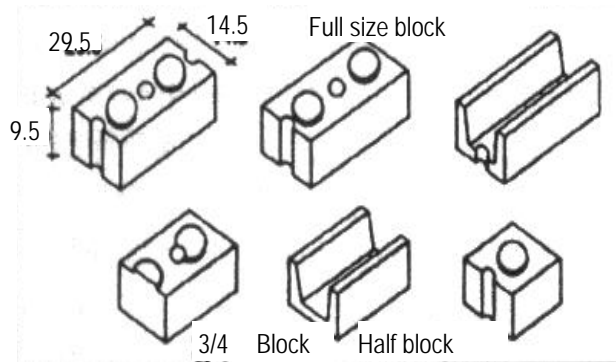

Variety of blocks 295

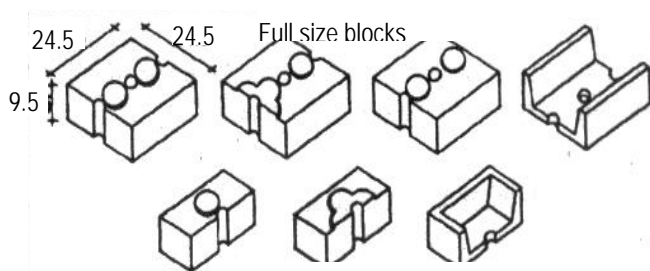

Half size blocks  
Variety of blocks 245

Source: Training manual on earthquake resistant buildings with hollow interlocking blocks published by the Auroville Earth Institute

## 4.5 bonds with blocks 245

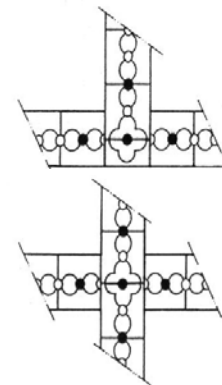
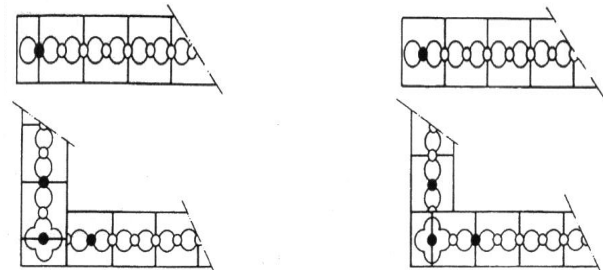

Odd courses

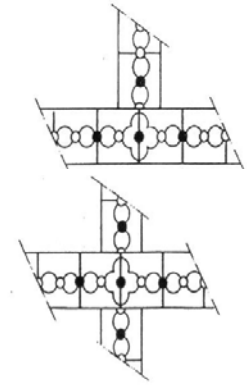

Even courses

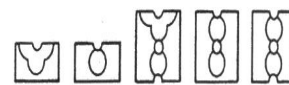

Block 245

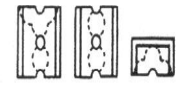

U Block 245