

STOVES FOR INSTITUTIONAL KITCHENS

Introduction to institutional stoves

Institutional stoves are used where larger amounts of food that can be accommodated on a standard kitchen stove can be cooked. Typical examples are schools, hospitals, prisons and other institutions. Institutional stoves are also used in refugee camps, particularly in the early stages when large influxes of people require food urgently. Typically, these groups will use institutional stoves with a cooking capacity of 50 litres to 200 litres.

Another very different group of users are entrepreneurs who own cafés or restaurants, selling street foods, or selling staple foods such as bread or chapattis. In such cases, the stove is likely to be used for several hours each day.

What makes a good institutional stove?

Fuel efficiency

- Where stoves are used in refugee camps, the acute shortage of fuel may be one of the reasons for choosing to cook communally.
- For an entrepreneur selling food, reducing the fuel costs can substantially increase his or her profit margin.
- In many countries, the cost of schooling or hospital treatment has to be borne by the consumer. Reducing the institutional overheads will bring down the cost of the service; particularly important to those on a low income.

Strength and quality

Heavy weights, such as a full urn of boiling water, will regularly be placed onto the stove. The stove must therefore be built to withstand such loads. When a stove fails, it not only stops production for that day, but can also lead to the entrepreneur's reputation for reliability being damaged. If livelihoods are dependent on cooking food, the stove must be reliable, sturdy and strong. It should last for several years and be easy to maintain in situ.

Low emissions

Where people are subjected to emissions for long periods, it is very damaging to their health. Those using institutional stoves will regularly be exposed to pollutants for many hours a day. Illnesses related to smoke inhalation include respiratory illnesses, eye discomfort and infections, there is some evidence of links with tuberculosis and heart disease and exposure of expectant mothers is implicated in low birth weight in infants.

Seasonal influences

If a stove can use a variety of fuels, it may be possible to use lower cost fuels, such as agricultural residues, at some times of year. However, a stove that relies solely on residues can only be appropriate if these residues are assured. Similarly, a solar cooker for institutional use is only appropriate where the sun shines all through the year and where most of the cooking is done during the day. Otherwise, a secondary stove will be needed.

When an organisation or individual is considering an institutional stove, other factors need to be considered:

- In refugee situations, the needs and preferences of those seeking help should be identified before a stove type is selected.
- A reliable supply chain for fuel should be assured, as the well-being of a lot of people will depend on the outcome.
- The stove could benefit a whole community or just the person with the stove; how are the benefits going to be distributed?
- Is the technology under consideration reducing the total emissions to the environment? If so, would it be possible to get carbon finance to support this activity?

Types of institutional stove

Rocket stoves

'Rocket-type' stoves are so-called because of their shape. They are rapidly becoming popular throughout the world and are particularly suited to institutional situations (see Case study 1). Rocket stoves depend on efficient combustion (through an internal 'chimney') and efficient heat transfer (through a narrow passage under the pot where the combustion gases must travel). Bread ovens can also be made using the rocket stove principle.

Case study 1: EcoStove – Nicaragua

In Nicaragua, an institutional stove has been developed based on the more traditional *plancha* stove, but using a rocket principle to create the EcoStove - a vented insulated stove. Above the fire is a *plancha* (a large metal griddle) which is heated both by the flames and by recirculated hot gases.



Figure 1: EcoStove in Nicaragua (photo: Rogerio de Miranda)

The benefits of using energy-efficient institutional stoves can be very great. The EcoStove from Nicaragua is an excellent example. Women there create small businesses cooking tortillas, soups and quick meals. Younger children will help to shape the tortillas and add fuel to the fire. Thus the whole family may be affected by smoke inhalation all day long.

The EcoStove stove consumes about one third of the wood previously used, making the sale of food much more profitable.

Since all the smoke goes out of the chimney, family health has also improved (*Boiling Point 47*).

In Africa, too, the rocket stove is having a major impact. To date (2007) more than 1,500 institutional stoves have been sold. This has been achieved through the development, by the organisation GTZ, of profitable stove production businesses, now thriving in Lesotho, Malawi and Uganda, with others starting up in Mozambique, Tanzania and Zambia.

Fuel wood savings are significant – conservatively, at least halved. One tea estate did a trial comparison of 100 litre pots of maize meal on their ‘rocket stove’ and an open fire, and found that the stove used only 10% of the firewood. A primary school in Mozambique has reduced its expenditure on fuel wood by more than half, and now has an additional US\$1,200 to spend on students educational needs.

Nkokonono stove

Rocket-type stoves are being introduced into schools in East Africa by the organisation GTZ. The Nkokonono stove, used in Lesotho, is typical of these stoves. The major challenge is to accommodate cooking pots that weight around 70kg and stand on three legs.

Built of steel and bricks, and insulated with vermiculite (a naturally occurring mineral), the stove burns less wood, reduces smoke exposure of cooks, cooks quicker, reduces drudgery through less time collecting wood and pot working height lifted to waist height.

Where rocket stoves are used for pots, one of the key features is to have a ‘skirt’ around the pot which drives the heat against the pot before it dissipates. For this reason, the pot is sunk into the body of the stove with a narrow space between the pot and the stove.

The resultant stove produces very little smoke (Figure 2 shows steam coming from the pot), and uses only a fraction of the amount of fuel using a standard three-stone fire (Figure 3).



Figure 2 Nkokonono stove (photo: Eco Ltd)

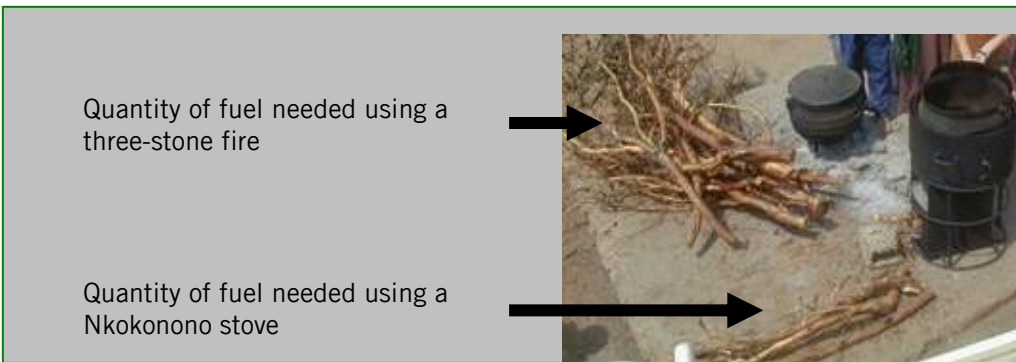

Figure 3: The use of an improved institutional stove can appreciably reduce fuel consumption (photo: Peter Scott)

Ovens

Food that needs baking requires an oven. The Tatedo bread oven is a good example of a small oven that can supply local needs and bring a good income to the person making the food. The oven is made of mild steel, aluminium, ceramic firebox and hotplates (Eco Ltd). It uses charcoal as a fuel.

The oven has a capacity to bake twenty-four 400 gram loaves of bread in 30 minutes using 600g of charcoal. By comparison, it would take two hours to bake ten similar-sized loaves with the traditional method (Sanga, GA).



Figure 4: Tatedo bread oven (photo: Eco Ltd.)

technical brief

The oven can be bought on credit and with a good market for bread, the profits can allow the entrepreneur to pay back the cost of the loan and still earn a good income.

Libhubesi stove



Figure 5: Libhubesi stove (photo: New Dawn Engineering)

This large stove is made from common materials, mostly 9 inch brick ‘seconds’ which are low cost, usually because they have not been fully fired (Pemberton-Pigott, C.).

A thin cement slab in the centre creates a hollow lower section supporting a 70 litre cast iron three-legged pot – favoured in Southern Africa when cooking for large groups. A kg of air-dried wood cooks over 8 kg of food.

The stove is built partly on rocket stove principles. It is unconventional because it has pre-heated air directed into the fire from the back of the stove provided by a heat conducting, high strength brick combustion chamber. The air is drafted downwards as it heats, improving stove efficiency and combustion. The robust fire chamber resists the impact of wood thrust against it.

Built by semi-skilled workers, the design is based on creating a pattern of bricks that can be memorised. It takes two days and is expected to last several years.

Emissions from the stove are low, producing little smoke, even when the fuel is damp.

Bellerive-type stove

This type of wood-burning stove is of a more traditional style, having been introduced into Eastern Africa in the 1980s. The Bellerive Foundation manufactured the stove to high quality control standards. The type of stove continues to be popular and similar ones (though not all of the same quality) are now produced by the private sector in Kenya, Uganda and Tanzania. They are also available in at least 16 schools in Malawi (Eco Ltd).

Constructed of mild steel sheet, cast iron, galvanised sheet and with a brick and clay lining, the stove required metal cutting, bending, rolling seaming and welding equipment for its manufacture. The resultant stove is fuel-efficient, reduces smoke exposure of cooks, cooks quickly, has a long life and requires little maintenance (Westhoff, B & Germann, D).

Although expensive (US\$1000) it has a long working life of around 10 years.

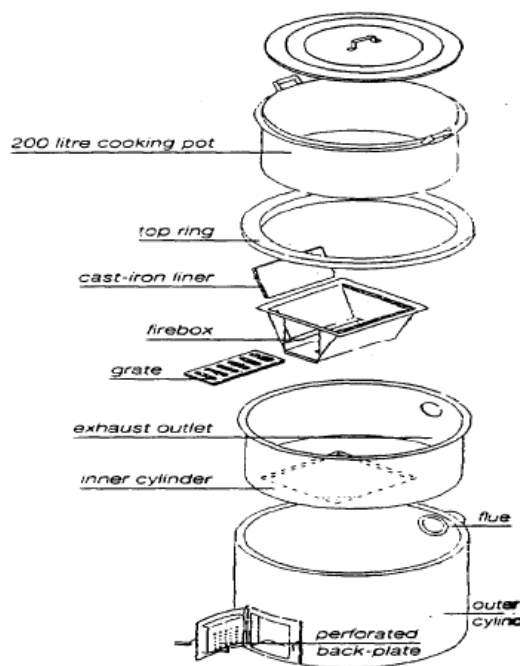

Figure 6: Bellerive type stove (photo: The Bellerive Foundation)

Injera stoves



Figure 7: Commercial Mirte stove
(photo: ESD)

Injera is the staple flatbread food for most Ethiopian and Eritrean households. It accounts for over 50% of all energy consumption in Ethiopia, and over 90% of all household energy consumption. The Mirte stove, developed by the organisation ESD, can save over half the wood fuel needed to bake it in the traditional way over an open fire. It also rids the cook of much of the pollution experienced in a traditional stove. This stove is a modular, prefabricated stove made from cement and local construction materials. It can be produced relatively easily, in large quantities, by a range of different scale producers, at inexpensive prices. The commercial bakers tend to be housewives who earn almost all their income from baking and selling injera to hotels, small restaurants and other households. Thousands of injera bakers have already purchased the Mirte. The Mirte saves commercial injera bakers over 3.5 tonnes of fuelwood per year, a savings of roughly £200 per year. This pays for the stove in days, and makes the sale of injera even more profitable for women bakers. It also protects them from smoke and flames, and saves Ethiopia scarce forestry resources (Judge, E.)

Stoves using peat

Two stoves are being promoted by the institutional peat stove programme in Burundi: the Burundian Community Stove (BCSt) designed for large pots of about 50cm diameter, and the Two-Pot Peat Stove for casseroles up to 27cm diameter. Features of the stove include:

- The stoves are built with bricks with a strong and heavy cast concrete top plate (5 to 7cm thickness). The bricks between the top plate and the ground foundation are laid with adobe, and the ground bricks for the foundation are laid with cement to protect the stove from ground water.
- The joints between the bricks are sealed with mortar which gives an outer strong and water-proof shell to the stove.
- The side and the back walls are built as double walls, filled with ash for insulation which enables the fire box to heat up quickly; necessary as peat burns smokeless only in a hot fire chamber.
- The pot is mainly sunken in the top of the stove so heat is transferred all around.
- The flue gas temperature in the chimney is about 200°C to keep the water simmering in a pot without a lid.
- The chimney is kept short to limit draft.

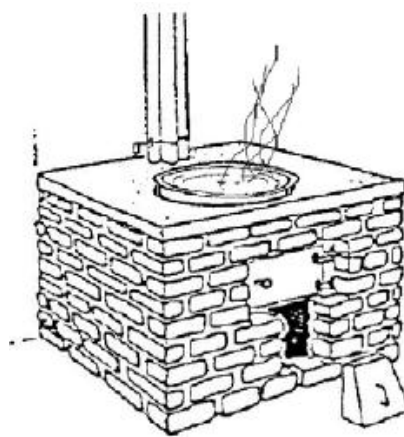

Figure 8: Burundi Community Stove
(Image: Project Tourbe II)

technical brief

Solar-powered cookers and ovens

A major requirement of solar cooking is, of course, plenty of sun, and where there is a pressing need for alternative energy. Large capacity institutional solar cookers are useful in relief projects as they can save tremendous amounts of cooking energy in group feeding situations such as shelters, orphanages, clinics, and schools. The most recent design, adopted by Solar Cookers International for refugee camps is the panel cooker. Its major features are low cost and increased portability, as the panels are hinged and can be folded up (Curtis, DO).

For small enterprises, the Villager Sun Oven, being disseminated by SUN OVENS International, is specifically designed to bake bread, cakes and pastries for sale in a specified geographic region. This oven reaches temperatures in excess of 260° C. This oven is specifically designed for bakery operations and has an effective life of at least 20 years. The oven is equipped with a propane back up system, which allows it to be utilized at night or during the rainy season (Sun Ovens International).



Figure 9: Villager Sun Oven (photo: SUN OVEN International)

Gasifier stove

Agricultural residues are often considered a problem, but if they can be burnt effectively they become an asset – (see Technical Brief *Paddy Husk & Sawdust Fired Industrial Stove*). Rice husk is a particularly problematic residue as it has a low calorific value (not much heat for a lot of fuel), but it is produced in very large amounts. An alternative way of burning fuels, called gasification, is allowing rice husk and other bulky fine residues to be burnt effectively as fuel.

The institutional size rice husk gas stove technology shown in Figure 10 can be used by restaurants, school canteens, small-scale processing industries, catering services etc. Rice husk is gasified inside the reactor, and the gas generated is ignited in the burner to produce a luminous controllable bluish flame for cooking (Belonio, A).

The stove consumes 14 kilograms of rice husk per load within 50 to 55 minutes of continuous operation. A small quantity of electricity, about the amount required by a light bulb, is needed to blow air into the mix. It takes around 1 minute for the stove to be started up, after which two 10-liter pots of water can be boiled in the stove within 18 to 23 minutes.

Advantages include:

- Ease of start-up and operation
- Almost no smoke and very little ash
- Low operating cost; rice husk and minimal electricity
- The by-product after gasification is a carbonized rice husk that is a good soil conditioner.

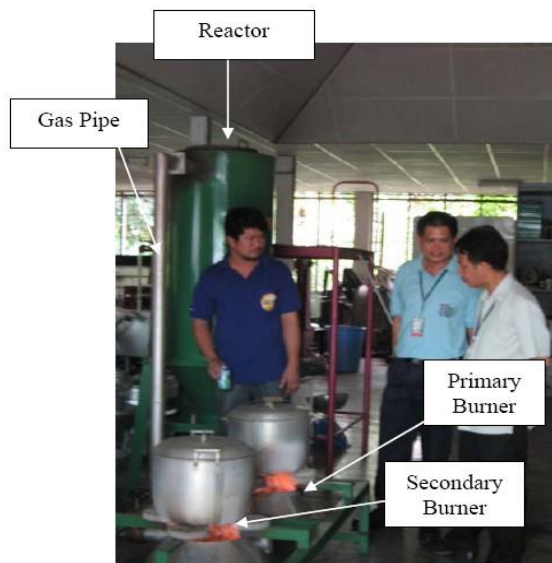

Figure 10: Bellonio institutional stove (photo: Belonio, A)

Impacts of institutional stoves

Institutional stoves have the potential for providing important services at a low cost to large numbers of people. They also provide employment through small locally-available services to communities. There has been a great deal of work done on institutional stoves over the last few years, resulting in several important impacts:

- Health – the new generation of institutional stoves provides energy which is cleaner and requires less effort to use.
- Environment – stoves with improved combustion require much less wood, thus benefiting the environment. Where residues can be used, two problems are solved at once – more fuel is available and the problem of what can be done with the waste is resolved.
- Employment – using more efficient stoves can make small enterprises very attractive to the entrepreneur as the profit margins can increase substantially
- Where those savings are passed on to the consumer, they pay less for the services
- Additional services, such as bakeries, can improve the quality of life for communities which are served
- Within a refugee situation, food can be provided quickly and efficiently, reducing the risks associated with fuel collection for traumatised people.

Conclusion

Institutional stoves have an important socio-economic role to play in society. Well-designed, they provide useful services to the consumer and a good income to the provider. They can also reduce overall fuel use within a community and improve the use of residues which would otherwise be a problem.

Further information

- *Institutional size rice husk gas stove* Belonio, A. Central Philippine University Iloilo City, Philippines
<http://www.crest.org/discussiongroups/resources/stoves/approtech/InstitutionalRiceHuskStove.pdf>
- *Solar cooking and health*, Curtis, DO in *Boiling Point 52 Health safety and household energy*, Practical Action, <http://www.hedon.info/View+Article&itemId=9034>
- *The modernization of small business through the EcoStove in Nicaragua* de Miranda, R. & Tilney, FG 'in *Boiling Point 47*, Practical Action, 2001
<http://practicalaction.org/docs/energy/docs47/BP47Miranda.pdf>
- Nicaragua, PROLEÑA EcoStove' de Miranda, R.
<http://stoves.bioenergylists.org/stovesdoc/Miranda/Ecostove/Ecostove.html>
- ECO Ltd. Private correspondence. Eco is a consultant firm based in London, UK, that brings together energy, sustainable development and information technology
<http://ecoharmony.com/Home>
- *Mirte stoves in Ethiopia* Judge, E. 'in *Boiling Point 41*, Practical Action (ITDG) 1998
- *Libhubesi - the lion - stove* Pemberton Pigott, C.
<http://stoves.bioenergylists.org/stovesdoc/Crispin/Libhubesi/libhubesi.html>
- *Baking a better life!* Sanga, GA in *Access [volume 3] February 2006*
http://www.ease-web.org/pdf/2006_access3_sanga.pdf
- *Rocket stoves for sub-Saharan Africa* Scott, P.
<http://stoves.bioenergylists.org/stovesdoc/Scott/subsahara.htm>
- *Sun Ovens International Micro-Sun-Bakeries: Creating Self-Sustaining, Self-Propagating Micro-Enterprise* <http://www.sunoven.com/around-the-world/sunovens/sun-bakeries>
- *Stove images – a documentation of improved and traditional stoves in Africa, Asia and Latin America* Westhoff, B & Germann, D. Pub. Brandes & Apsel Verlag GmbH, Frankfurt am Main, Germany, 1995. <http://www2.gtz.de/dokumente/bib/97-0616a.pdf>

Websites

The HEDON Household Energy Network is an informal forum dedicated to improving social, economic, and environmental conditions in the South, through promotion of local, national, regional and international initiatives in the household energy sector. <http://www.hedon.info/>

Stoves website: A vast number of technologies, images and discussions can be found at this site <http://www.crest.org/discussiongroups/resources/stoves/cookstoves2005.html>

Practical Action
The Schumacher Centre for Technology and Development
Bourton-on-Dunsmore
Rugby, Warwickshire, CV23 9QZ
United Kingdom
Tel: +44 (0)1926 634400
Fax: +44 (0)1926 634401
E-mail: inforsew@practicalaction.org.uk
Website: <http://practicalaction.org/practicalanswers/>

This document was produced by Dr. L Bates for Practical Action in March 2007

Practical Action is a development charity with a difference. We know the simplest ideas can have the most profound, life-changing effect on poor people across the world. For over 40 years, we have been working closely with some of the world's poorest people - using simple technology to fight poverty and transform their lives for the better. We currently work in 15 countries in Africa, South Asia and Latin America.

technical brief