

BICYCLE AMBULANCE

An Introduction

This document looks at the bicycle ambulance developed by Practical Action, Nepal. It has been design to be used on the *terai*, the flat marshy lands at the base of the Himalaya mountain range.

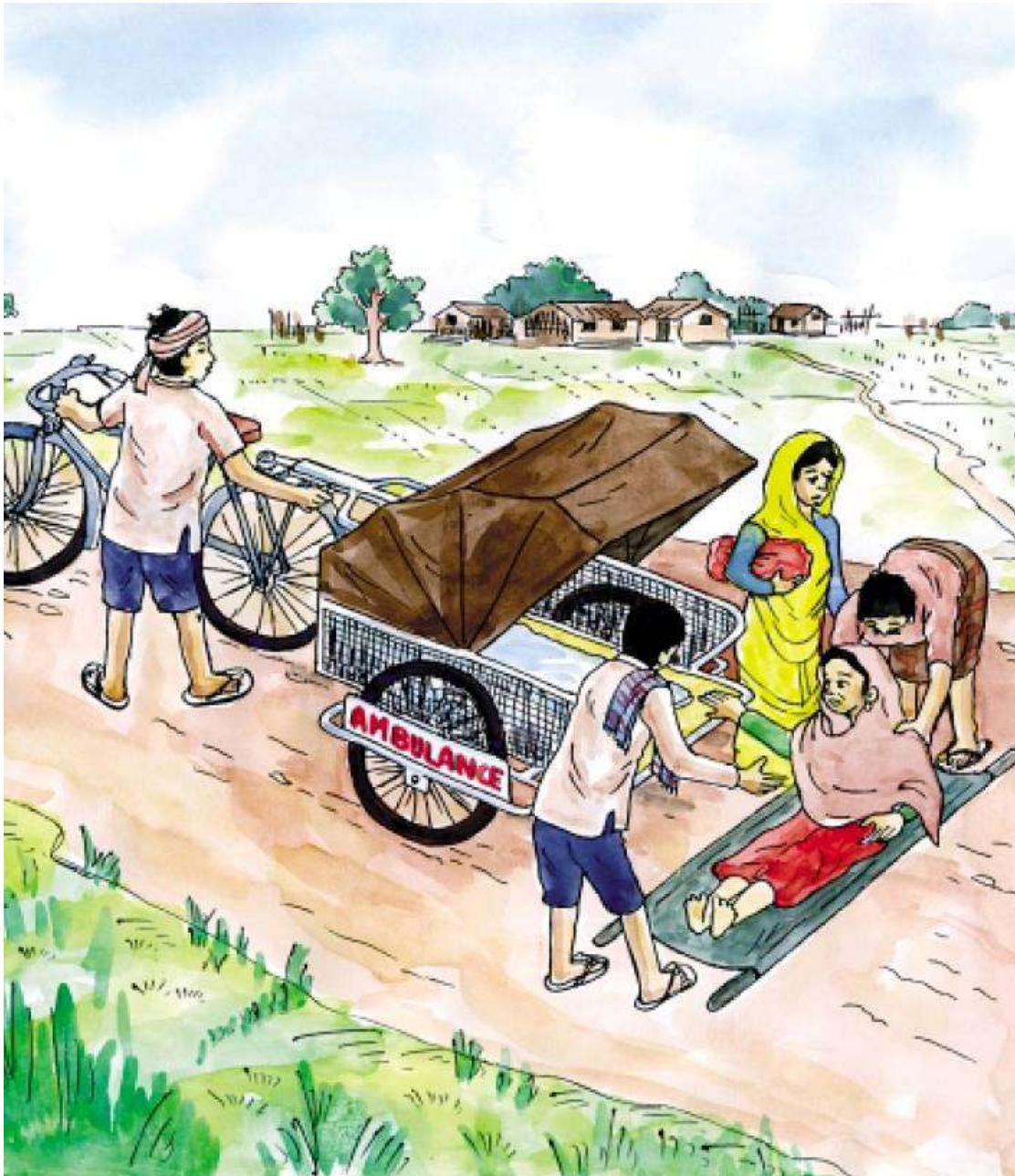

Practical Action, The Schumacher Centre, Bourton on Dunsmore, Rugby, Warwickshire, CV23 9QZ, UK
T +44 (0)1926 634400 | F +44 (0)1926 634401 | E infoserv@practicalaction.org.uk | W www.practicalaction.org

Practical Action is a registered charity and company limited by guarantee.
Company Reg. No. 871954, England | Reg. Charity No.247257 | VAT No. 880 9924 76 |
Patron HRH The Prince of Wales, KG, KT, GCB

1. Introduction

Rural parts of Terai have no access to public transport and to own a personal vehicle is not possible because of their poor economic status. Thus, local people highly value the alternative emergency transport services. Bicycle Ambulance is one of those alternative transport services which has made it possible to reach the patients to the nearest health post on time.

Bicycle ambulance has been considered highly useful in the plain/ rural areas of terai because it can be privately operated by local community. Its importance has further increased because this ambulance can be used even at the time of frequently occurring strikes.

This cycle has space enough to carry 2 people. A shock absorber is fitted in the cycle to make the ride as much comfortable as possible for the patient. The trolley and bicycle is attached to each other with the use of clamp system. This trolley can be handled easily even in the turnings due to the presence of Ball joint in the clamp. An ambulance cover is also fixed to guard them from sun, rain and storm. As the Ambulance cover is attached by the rebating, it can be easily opened and closed as per the need.

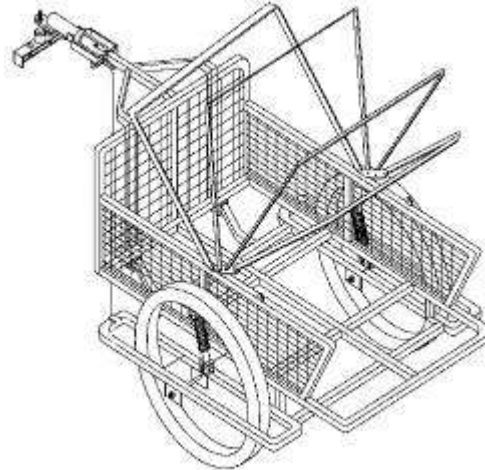

Bicycle Ambulance

The following are the required equipments to construct a bicycle ambulance:

- Wheel
- Braking system
- Shock absorber
- Clamp system
- Lower frame
- Upper frame
- Knot bolt and other equipments

All the essential equipments for bicycle ambulance are easily available in the local market. It has added the importance taking into consideration its use in the internal roads and rural villages of Terai area.

2. Why Bicycle Ambulance?

Following are the benefits from the Bicycle Ambulance:

- It is a simple alternative scheme for the carrying the patients to and from the nearest health post.
- When considering the investment, management and operation of this ambulance, it is very cheap which increases the possibility to be used in a private manner as well.
- Patients can be taken to the health posts even at the time of strikes without any kind disturbances.
- It is accessible to the people of poor economic status because it is simple and less expensive technique.
- It does not have any engines installed in it, so there is no negative impact in the environment.

- Its construction is uncomplicated as the required equipments are easily available in the markets of Terai.
- It can be constructed easily even at local level.
- The technique is very easy for its handover.
- There is no requirement of any fuel and uses high number of local labours.

3. Essential equipments for bicycle ambulance

3.1 Clamp system

Front part of the cycle and the lower frame of the bicycle ambulance is joined with the help of clamp. Two M.S. Flat is attached with the carrier of cycle and is tightened using a knot bolt. To avoid any difficulty for the patient while turning the handle of the cycle, a ball joint is used in the upper clamp which makes it easy to turn the cycle. Ball joint of cylinder shape with 40 mm radius is joined by welding it to M.S. Flat.

Following are the elements required to construct a clamp system:

- Knot bolt of 10 × 60 mm- 2 pieces
- M.S. Flat of 215 × 40 × 40 × 5 mm- 1 number
- M.S. Flat of 190 × 40 × 5 mm- 1 piece
- Ball joining system of 117 mm height
- Knot bolt of 12 mm

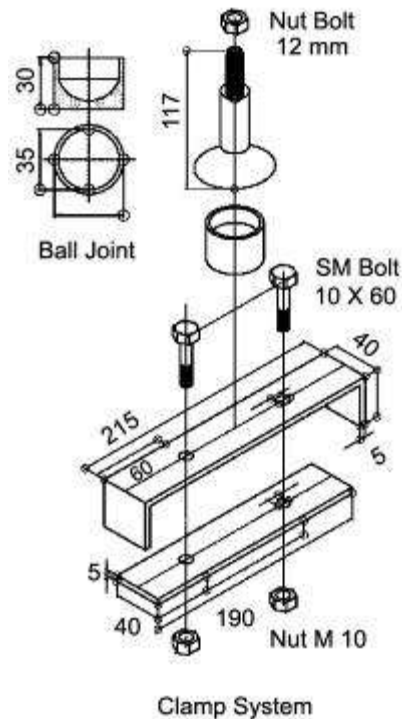

3.2 Braking System

Braking system is used to balance the speed and to have complete control at the time of emergency. It uses a cylindrical pipe of 45 mm radius. At the later end of the pipe, a 25 mm knot bolt is used to fix a spring inside the pipe. In the middle of a spring of size 3×22×50 mm, a 4 mm thick M.S. Flat is used to avoid it from losing its working capacity. When a driver uses a break, the Guide shaft enters into the cylinder which causes the brake wire to stretch. This leads to the contraction of brake lever. And finally, the break shoe holds the ring of the wheel which eventually controls the speed.

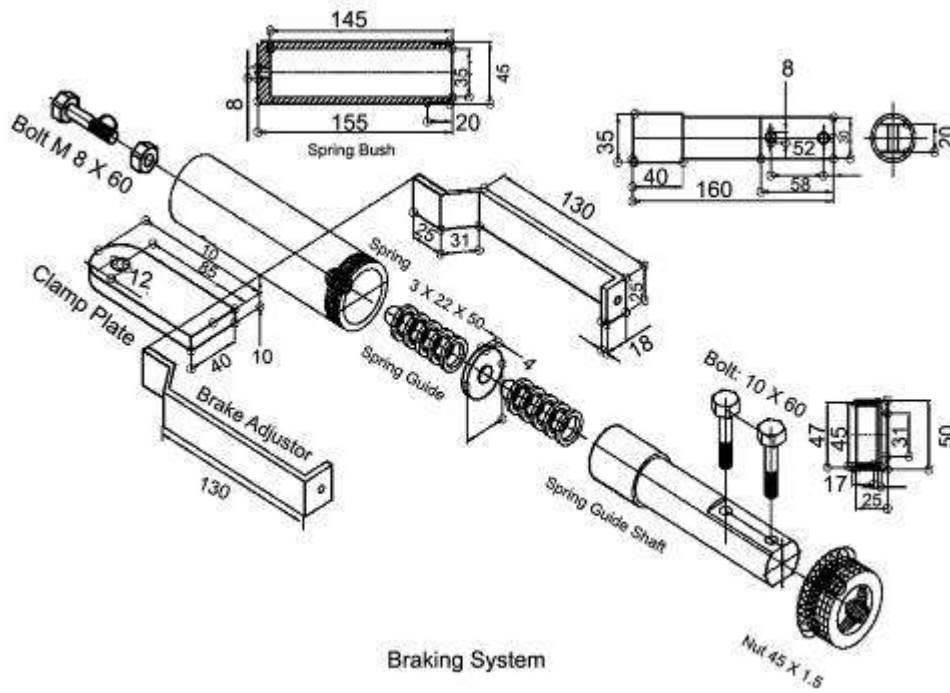

Braking System

Braking system requires the following mentioned elements:

- Knot bolt of 8 × 60 mm
- Spring of 3 × 22 × 50 mm
- Cylinder of 145 mm length and 45 mm outer radius
- Spring adjuster of 130 mm length
- Clamp plate
- Spring guide
- Brake wire

3.3 Ambulance cover

An ambulance cover is used to protect the patients from sun, rain and storm. M.S. Flat is joined by rebating at the centre of the upper part of upper frame. This helps in opening and closing of the ambulance cover. This cover can be made using plastic or cloth as per its availability and need.

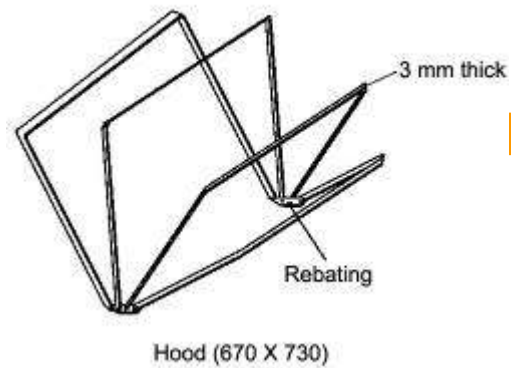

technical brief

3.4 Lower frame

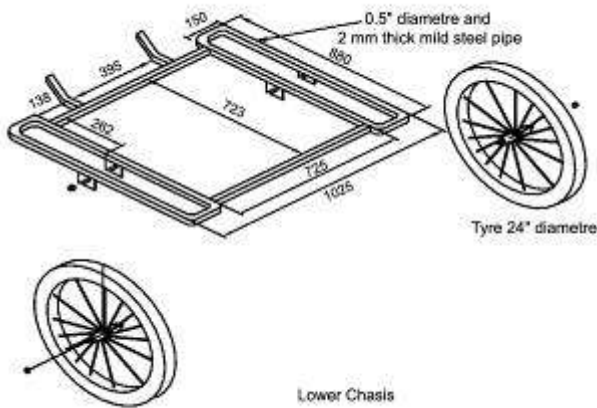

Lower frame is the lower part of bicycle ambulance. As shown in the diagram, according to the need, a frame is prepared by welding the mild steel. On the both side of the frame, a wheel is placed and is tightened using a knot bolt. A shock absorber is placed in the middle of upper and lower frame. This helps to have a comfortable ride for the patients when the bicycle ambulance is operated at speed. This equipment is joined by a hinge and along with it upper and lower frame is also joined hinge. The upper part of hinge is joined into upper frame by welding it.

3.5 Ball joint

Ball joint is joined by welding in the clamp plate of carrier of the cycle bicycle whereas the lower part of the cylinder of 40 mm radius is joined by welding it to the upper part of the clamping plate. A ball of 35 mm radius is kept inside this cylinder. This ball has the ability to easily rotate inside the cylinder, thus changing the direction of the trailer along with the change in the direction of the cycle which helps in having a comfortable ride to the patient. This provides a movable joint between the cycle and the trailer making the ride smoother.

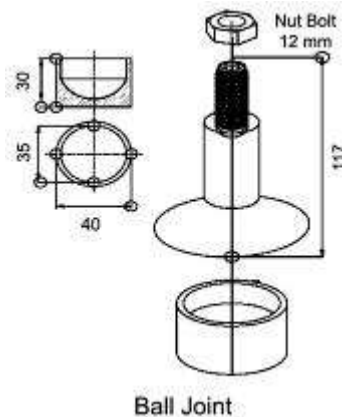

3.6 Shock Absorber

This part of the cycle reduces the shock that is generated by speeding up the ambulance and makes the journey comfortable enough for the patients. While travelling in the difficult, gravelled and trail roads, the spring attached to the shock absorber contracts and reduces the generated shock. The upper part of the shock absorber is welded to the centre part of the frame with the help of a knot bolt of 12 mm radius and a bus of 28 mm length. The lower part is joined to the square pipe of the lower part of frame using a knot bolt brush.

The required elements for shock absorber as mentioned below:

- Bus (28 mm length, 25 mm radius)
- Hinge
- Knot bolt (14 mm radius, 60 mm length)
- Spring

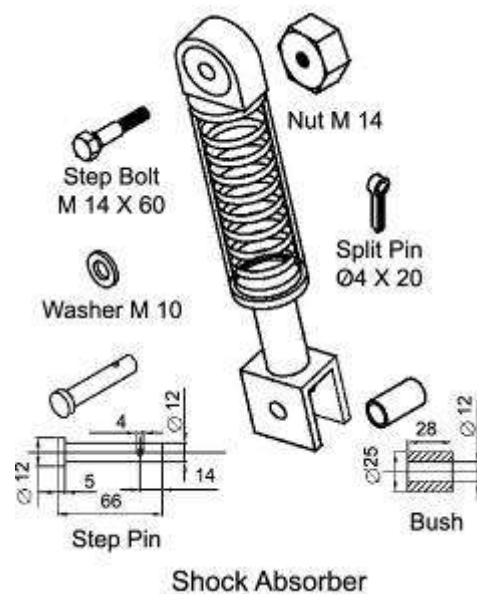

technical brief

3.7 Wheel

There are three wheels in bicycle ambulance including the ones in ambulance carrier and cycle. Generally, the radius of the wheels has a radius of 24 inch.

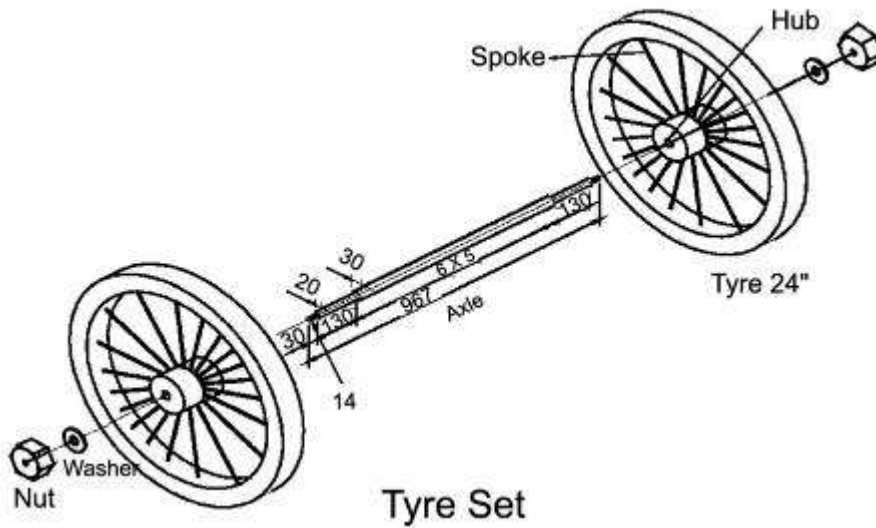

The elements required for the wheel are mentioned below:

- Axle
- Hub
- Spoke
- Tyre

3.8 Hinge

The different parts of the ambulance are joined using a hinge. To join the hinge, u-bracket as shown in the figure, knot bolt and bus are required. This hinge allows the different parts of the ambulance to bend.

The following are the required elements for hinge:

- U-bracket
- Bolt (radius of 10 mm and length of 60 mm)
- Knot (radius of 10 mm)
- Bus (2 mm length, 15 mm radius)

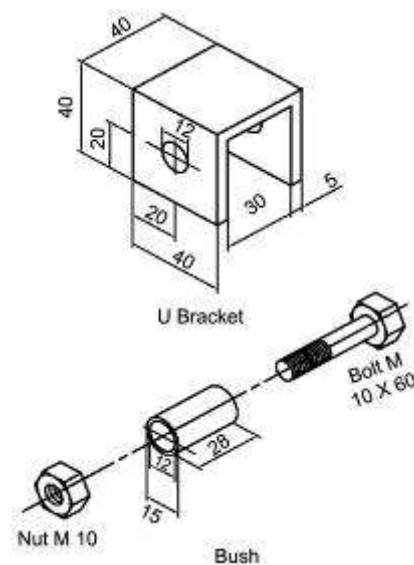

4. Management process of Bicycle Ambulance

Normally, Bicycle Ambulance is not required frequently, so it is suitable to be constructed, maintained and operated by a group. For its sustainable operation and management, following points are to be taken note of:

- Commitment should be provided for the participation of continuous operation and appropriate management of the bicycle ambulance.
- User committee should be formed by including representatives from the user community.
- As per the need, members of user committee should meet to find the solutions of the problems and to find the solid conclusion with discussion in relation to its management.
- At the beginning of this project, a fund should be created from the contribution of the user community.
- All the users should contribute to the management fund as fixed by the committee, for the use in its maintenance and operation.
- When it is not used, it should be made available for rent and can be used to earn money out of it. It should be managed in such a way that there will not be any disturbances at the time of emergency.
- All the members of the committee should be actively involved for the required management.

4.1 Maintenance

- To avoid the friction, oiling should be done at a regular basis.
- The wheel should be regularly cleaned as thread, cloth and hair can be entangled in it.
- Knot bolt should be checked at least once every week.
- Bicycle ambulance should be kept in shade to save it from dust, sun rays or other types of pollutants.
- The bus of the hinge should be oiled at least once a week (if possible daily).
- The axle and hub of the wheel should be oiled at least once a week (if possible daily).
- If there is any unusual sound produced from the cycle, it should be immediately checked and repaired.
- Oil or grease should be used daily in the brake system.

4.2 Daily operation and maintenance

- To avoid friction, grease, Mobil gel or any other type of oils should be applied in the clamp system, shock absorber, hinge, joint and braking system before its daily operation.
- Maximum 2 persons should be allowed in the bicycle ambulance.
- Bicycle ambulance should be placed in safe area after its use. It should be kept at a place having a roof to protect it from sun rays and rainwater.
- All the accessories of the bicycle ambulance should be checked before its use.
- If there is problem in any accessories, it should be repaired or changed.
- If there is any kind of unusual sound in its operation, it should be checked immediately.

4.3 Oiling

Oiling should be done very weak in the clap system, every fortnightly in the shock absorber, every 7 days in hinge and every day in brake system. Grease or any other kinds of lubricant should be injected using grease injection gun.

4.4 Solution to probable problems

Following solutions should be applied if there is some problem in the ambulance:

- All the systems of the ambulance should be monitored. If there are unfastened or missing knots, it should be tightened or changed accordingly.
- If there is jam or some portion has rust, grease or other lubricants should be used.
- If the operator is unable to fix the problem, one who is involved in its creation should be contacted and fixed as per their advice.

4.5 Conditions for the change of equipments used in bicycle ambulance

When the following conditions are seen, parts of the ambulance should be changed:

- I. If there is any unusual sound in operation or if there is no progress after maintenance
- II. If there is break in brake wire
- III. If hinge is broken
- IV. If the plastic seat or cover of the ambulance cover tears
- V. If the thread of bolt is out of order or if the knot breaks
- VI. If the spring of the braking system breaks

5. Initial investment

Almost NRs. 6000 to NRs. 8000 is required for the manufacture of bicycle ambulance. Actual cost differs according to the quality of the used materials, service charge of the manufacturer and transportation charge required to reach it to operation site from construction site.

6. Organisations related to manufacture, operation and maintenance of bicycle ambulance:

Many people have information about vehicles, but there are only few who has the information about the alternative vehicles like bicycle ambulance. Information related to the organisations who are involved in the manufacture of the bicycle ambulance can be collected from International Non-Governmental Organisation, Practical Action Nepal, Lazimpat. Likewise, information related to this system can also be collected from the local manufacturers who were initiated by Practical Action Nepal. The name, address and contact details of some of the major organisations are mentioned below:

Mr. Bijay Bahadur Shrestha
Bijay Engineering Works
Anchalpur, Ward no. 9
Bhairahawa, Nepal
Tel: 071-520613, Fax: 071-520613

Mr. Rajendra Shrestha
ATMGMI
Balaju 16, Kathmandu
Tel: 4256191, Mobile: 9851044072
Email: rshrestha@mail.com.np

Further reading

[*Design of Bicycle Trailers*](#) M Ayre Practical Action Publishing 1986

[*Bicycle Trailers*](#) Technical Brief Practical Action

[*Bicycles*](#) Technical Brief Practical Action

This document was translated by Rijana Malla for Practical Action, Nepal 2010, from the [original document in Nepali](#).

Practical Action Nepal
P O Box 15135, Kathmandu, Nepal
House no. 2677
Phone: +00 977 1 4720 803 Fax: +00 977 1 4720 402
Email: info@practicalaction.org.np
Web: www.practicalaction.org

Practical Action is a development charity with a difference. We know the simplest ideas can have the most profound, life-changing effect on poor people across the world. For over 40 years, we have been working closely with some of the world's poorest people - using simple technology to fight poverty and transform their lives for the better. We currently work in 15 countries in Africa, South Asia and Latin America.

technical brief